

Suspended ceilings

While NZS 4219:2009 *Seismic performance of engineering systems in buildings* provides guidance for suspended components, including plant and equipment in the suspended ceiling space, it specifically excludes the suspended ceilings themselves.

SUSPENDED CEILINGs should instead be designed and constructed in accordance with NZS 1170.5:2004 *Structural design actions – Part 5: Earthquake actions – New Zealand* and AS/NZS 2785:2000 *Suspended ceilings – Design and installation*. AS/NZS 2785:2000 cites the seismic demand calculations in NZS 4203, but this has been superseded by NZS 1170.5:2004. This provides a mechanism to comply with the Building Code requirements for the seismic design of suspended ceilings in commercial, industrial and residential buildings.

AS/NZS 2785:2000 design pathways

Like NZS 4219:2009, AS/NZS 2785:2000 allows both specific and non-specific pathways to design a suspended ceiling system. Unlike NZS 4219:2009, the pathway chosen depends on the seismic demand determined by NZS 1170.5:2004. This takes into account the location and importance of the building, component categories and requirements of the ceiling being designed.

This information and AS/NZS 2785:2000 are then used to determine whether the suspended ceiling requires a specific design or if a non-specific design will be sufficient.

Non-specific design

Non-specific design guidance, which is usually provided by the suspended ceiling manufacturer, may be used to achieve a compliant design. The guidance must be certified to comply with the requirements of the Building Code by a New Zealand-based seismic specialist.

Non-specific design guides typically provide a prescriptive solution to calculate



the seismic restraint requirements for the type of ceiling being considered. If a non-specific design is derived from the ceiling manufacturer's guidance, all the working sheets (which must be part of the guidance) should be submitted as part of the PS3 producer statement.

Specific design

More complex projects will require a specific design, which must be conducted by an experienced and suitably qualified seismic specialist or ceiling designer. A suspended ceiling may require a specific design for a number of reasons, including:

- complexity of the ceiling
- size of the ceiling
- building importance level
- floor to ceiling height

- ceiling to structure height
- other building components in the ceiling
- working life of the design.

Seismic demand

Irrespective of the pathway chosen, all suspended ceiling designs must be able to accommodate the seismic demand calculated using NZS 1170.5:2004.

Lightweight suspended ceilings are typically classed as component category P7 (see Fact Sheet 2 Design criteria), which requires design to the lowest level of seismic demand.

All suspended ceilings must be designed to support ceiling-mounted distributed services up to a load of 3 kg/m² under seismic conditions. Where service loads are greater than 3 kg/m², the ceiling designer should be advised.

Table 6.1 Seismic grades for suspended ceilings (from the AWCI Code of Practice for Design, Installation and Seismic Restraint of Suspended Ceilings, October 2015)

Seismic grade	Description
AWCI SG1	<ul style="list-style-type: none"> • Ceiling in a building with low seismic performance requirements with ceiling component category P7 and SLS1 (up to building importance level 3). • Not requiring specific engineering design.
AWCI SG2	<ul style="list-style-type: none"> • Ceiling in a building with low seismic performance requirements with ceiling component category P7 and SLS1 (up to building importance level 3). • Within design parameters of relevant manufacturers' standard type-tested designs but not requiring specific engineering design. • PS3 with supporting documents.
AWCI SG3	<ul style="list-style-type: none"> • Ceiling in a building up to building importance level 3 or component category P4 where ceilings must be designed for ULS, in public spaces, forming part of an emergency egress way, supporting life safety systems or at high level. • May be within design parameters of relevant manufacturers' standard type-tested designs, but specific engineering design is required. • Minimum of PS1 and PS3 with supporting documents.
AWCI SG4	<ul style="list-style-type: none"> • Ceiling in a building up to building importance level 4 or component category P4 where ceilings must be designed for ULS, in public spaces, forming part of an emergency egress way, supporting life safety systems or at high level. • Specific engineering design is required. • Minimum of PS1, PS3 with supporting documents and PS4.

Where the suspended ceiling supports equipment or has components that weigh 10 kg or more that could fall more than 3 m onto a publicly accessible area, the suspended ceiling system should be classed as component category P3 (or P2 for an auditorium).

Seismic grade

The Association of Wall and Ceiling Industries of New Zealand (AWCI) has developed a seismic grade from 1–4 to describe the seismic requirements of suspended ceilings (Table 6.1). This reflects an incremental step in grid strength, shop drawing requirements, type and extent of seismic restraint, requirement for specific engineering design and involvement of independent seismic specialists.

Restraint systems

All suspended ceiling systems should be designed with sufficient seismic restraint to enable the ceiling to carry the seismic demand load.

New Zealand buildings commonly use two types of suspended ceiling – perimeter fixed and floating. In both cases, vertical restraint is often provided by the force due to gravity on the suspended ceiling itself. However, rigid vertical struts may also be required, depending on the seismic zone and the ceiling-to-structure heights.

Perimeter-fixed ceilings

Perimeter-fixed ceilings are suspended using vertical wire or cable hangers and laterally restrained by anchoring the edges of the ceiling to the surrounding wall, frame or other

structural element. Ceilings of this type are not normally braced.

A perimeter-fixed ceiling should be anchored at the ends of two orthogonal edges of the ceiling grid, maintaining a 10–15 mm sliding clearance at the opposite edges (Figure 6.1). The free ends must be able to move (slide) against the wall but still be sufficiently restrained to prevent the grid or tiles collapsing. This is typically achieved with a channel moulding or proprietary fixing.

Floating ceilings

If perimeter fixing is insufficient for the seismic demand, the ceiling must be restrained to the structure using another method. Floating ceilings are braced to the underside of the floor above to provide lateral restraint.

They are not connected to the perimeter wall or frame. The gap between the ceiling and the surrounding wall has to be sufficiently large that the ceiling is not damaged by impacts against the wall during an earthquake. All step changes in ceiling height must also be adequately braced.

Vertical suspension may be provided using wire or cable hangers, or vertical struts constructed from angles, metal studs or proprietary compression posts anchored to the ceiling grid and the building structure.

Lateral bracing in a floating ceiling can be provided by using rigid braces, cable braces (splay wires) combined with vertical struts or a combination of these techniques.

In a floating suspended ceiling, joints in the main tees should not be placed within 150 mm of any vertical hanger, strut or bracing connection point.

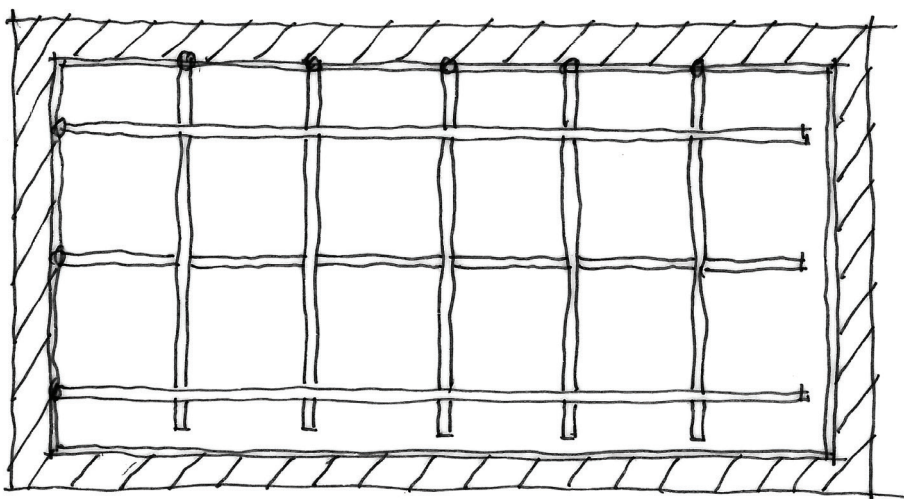

Figure 6.1 Perimeter-fixed suspended ceilings are typically anchored along two orthogonal edges and restrained with sliding joints on the others.

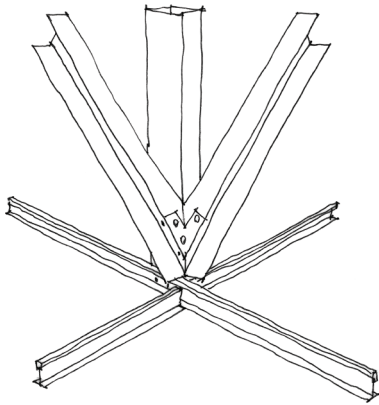

Figure 6.2 Bracing requirements for strut-connected braces in a floating suspended ceiling system restrained with sliding joints on the others.

Rigid braces

Rigid braces should be installed in pairs orthogonal to each other and in combination with a vertical hanger or strut (Figure 6.2). They should be at a maximum angle of 45° from the plane of the ceiling grid. The braces should be as close to the same vertical plane as the main and cross tees as possible.

Rigid braces may connect to vertical struts or the ceiling grid, but braces that connect to the ceiling grid should be fixed within 50 mm of a vertical strut connection point. If four rigid braces are used – two in each orthogonal direction – the vertical strut may be omitted.

Cable and wire braces

Cable-only and wire-only braces are not as inflexible as rigid braces, but their performance is improved by using them in conjunction with vertical struts.

Cable braces should be connected between the main tee and the building structure at a maximum angle of 45° from the plane of the ceiling grid (Figure 6.3). Four orthogonal cables should be installed, one pair on either side of each vertical strut. Each pair should be connected to the main tee as close to the vertical strut as possible, and the cable fixings in each pair should be no more than 100 mm apart.

Hangers

Hangers must maintain a horizontal clearance of 50 mm from restrained components and services and 150 mm from unrestrained components and services in the ceiling space

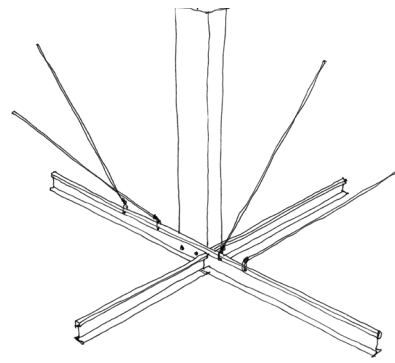

Figure 6.3 Bracing requirements for cable and wire braces in a floating suspended ceiling system.

(as required by NZS 4219:2009).

A bridging system should be used where the correct clearances cannot be achieved or suitable hanger points cannot be accessed because of obstructions in the ceiling space.

Hangers should be spaced at centres of no more than 1.2 m and be within 9.5° of vertical (1:6), unless using counter-sloping wires. Floating terminal ends of each main and cross tee should be supported with a perimeter wire located within 200 mm of each wall.

Wire and cable hangers should be 2.5 mm in diameter, with top and bottom connections secured using at least three complete tight turns extending no more than 75 mm along the cable.

Disclaimer: The information contained within this publication is of a general nature only. BRANZ does not accept any responsibility or liability for any direct, indirect, incidental, consequential, special, exemplary or punitive damage, or for any loss of profit, income or any intangible losses, or any claims, costs, expenses, or damage, whether in contract, tort (including negligence), equality or otherwise, arising directly or indirectly from or connected with your use of this publication, or your reliance on information contained in this publication.

ISSN 2463-672X

Copyright © BRANZ 2016. No part of this publication may be photocopied or otherwise reproduced without the prior permission in writing from BRANZ.