

# BULLETIN



December 2005

NUMBER 468

## FIXING TIMBER WEATHERBOARDS



- ❑ Successful use of timber weatherboard claddings is dependent on careful timber and profile selection and correct fixing.



## 1.0 NEW ZEALAND BUILDING CODE

1.0.1 Timber weatherboards must, under the New Zealand Building Code (NZBC):

- withstand the forces acting on them
- protect people and the building structure from the effects of moisture entry.

1.0.2 The way timber weatherboards are installed is critical in meeting the above objectives. Some requirements for fixings are given in:

- E2/AS1 Third Edition of NZBC, Table 24
- NZS 3604, Section 11.

1.0.3 Fixings other than those in the Acceptable Solutions must meet an equivalent or better level of performance to be consented as an Alternative Solution.

## 2.0 WEATHERBOARD SELECTION

2.0.1 Profiles for timber weatherboards are given in NZS 3617 *Specification for profiles of weatherboards, fascia boards and flooring* and in BRANZ *Bulletin 411*.

2.0.2 Grade, type and treatment of timber weatherboards are given in NZS 3602 *Timber and wood-based products for use in building*.

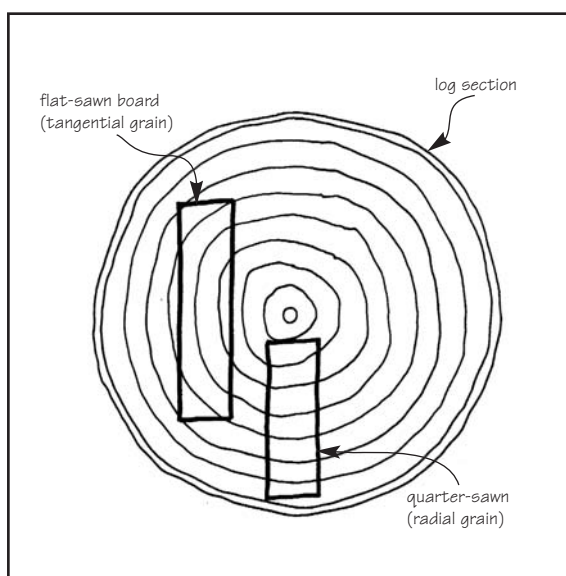

Figure 1. Direction of grain in sawn boards.

2.0.3 Weatherboard profiles outside the scope of E2/AS1 must be considered as an Alternative Solution.

2.0.4 Weatherboards will perform better when they:

- are a minimum of 19 mm thick with weathergrooves and rebates, where required
- have correct overlap dimensions, where applicable
- have all surfaces coated, preferably painted in a light colour
- have an expansion gap left between rebated boards
- are correctly set out
- are installed horizontally rather than vertically as the weathering laps are in the direction of water shedding
- are quarter-sawn as opposed to flat-sawn – especially on exposed (north and west) sides of the building (see Figure 1).

## 3.0 CAVITY REQUIREMENTS

3.0.1 Timber weatherboards are either direct-fixed onto framing, or fixed over a cavity onto vertical battens.

3.0.2 For designs following E2/AS1, Table 3 of the Acceptable Solution allows for the following risk scores:

- 0-6 – direct-fixing of all types of timber weatherboards
- 7-12 – direct-fixing of bevel-back and board and batten (rusticated weatherboards must be fixed over a 20 mm drained and vented cavity)
- 13-20 – bevel-back and rusticated weatherboards must be fixed over a 20 mm drained and vented cavity.

3.0.3 Board and batten, being narrow vertical cladding components, cannot be fixed over a cavity but can be direct-fixed up to risk score 13.

### 3.1 Fixing cavity battens

3.1.1 Cavity battens can be:

- initially nailed lightly to the studs, and then the weatherboards are nailed through the battens into the studs
- laminated to the wall framing (refer BRANZ Test Report ST0589).

### 3.2 Laminating battens

3.2.1 Laminating battens to the framing allows the use of shorter and lighter gauge nails to fix the weatherboards to the battens and reduces the risk of weatherboards splitting. Use of laminated battens must be assessed as an Alternative Solution.

3.2.2 Battens shall be fixed at 300 mm centres staggered 12 mm either side of the batten centreline, using hot-dip galvanised nails, either:

- hand-driven 60 x 2.8 mm jolt or flat head nails, or
- hand-driven 75 x 3.15 mm jolt or flat head nails, or
- power-driven 64 x 2.8 mm jolt or flat head nails.

3.2.3 Battens must be No.1 framing grade radiata pine, kiln dried with a maximum thickness of 20 mm and a minimum width of 40 mm.

## 4.0 FIXING WEATHERBOARDS

### 4.1 Fixing positions

4.1.1 As timber expands and contracts with changes in moisture content, correct nailing is necessary to accommodate this movement without the boards splitting or buckling (see photos on page 7).

4.1.2 For each of the weatherboard types (shown in Figures 2 to 8):

- use only one nail per board width at each fixing point, to allow the board to move
- locate nails in horizontal profiles 10 mm above the lap
- locate nails in vertical profiles 10 mm from the lap
- for 19 mm thick weatherboards, fix horizontal boards at 600 mm maximum centres (that is, at every stud) and vertical boards at maximum 480 mm centres
- pre-drill weatherboards (to avoid splitting) for nail locations within 50 mm of board ends – when hand-driven.

### 4.2 Fixing sizes

4.2.1 Direct-fixed weatherboards are required by NZS 3604 to be fixed to studs with hot-dip galvanised nails (see Table 1).

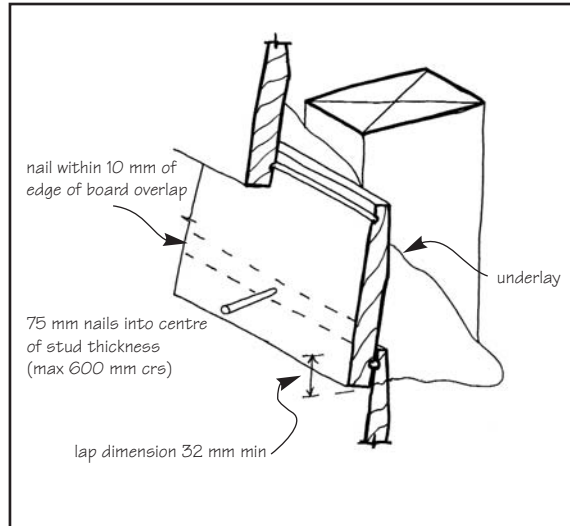

Figure 2. Bevel-back boards direct-fixed.

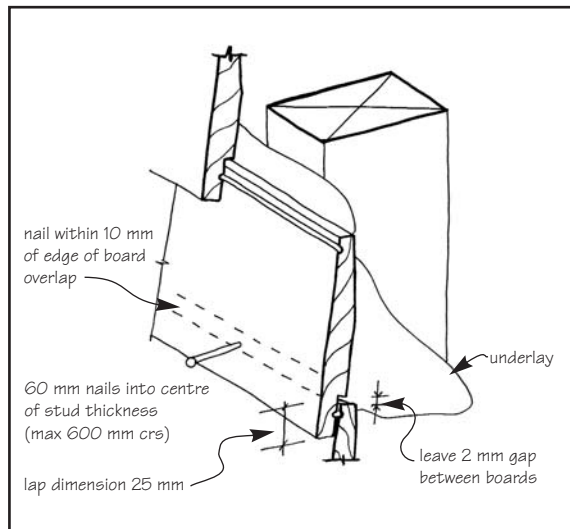

Figure 3. Rebated bevel-back boards direct-fixed (Alternative Solution profile).

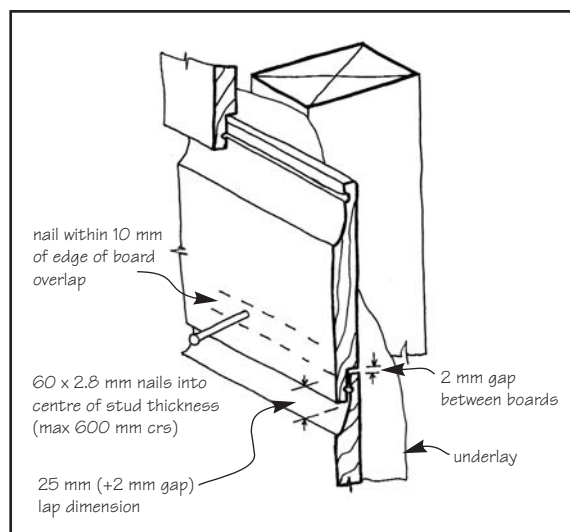

Figure 4. Rusticated boards direct-fixed.

4.2.2 When fixing horizontal weatherboards over battens, nail through the battens and into the mid-width of the studs using hot-dip galvanised nails (see Table 1).

4.2.3 When fixing weatherboards to laminated battens, follow the requirements for direct-fixed weatherboards (see Table 1).

4.2.4 Figures 2 to 8 show galvanising jolt head nails. Smaller sizes are available with annular groove nails (see Table 1).

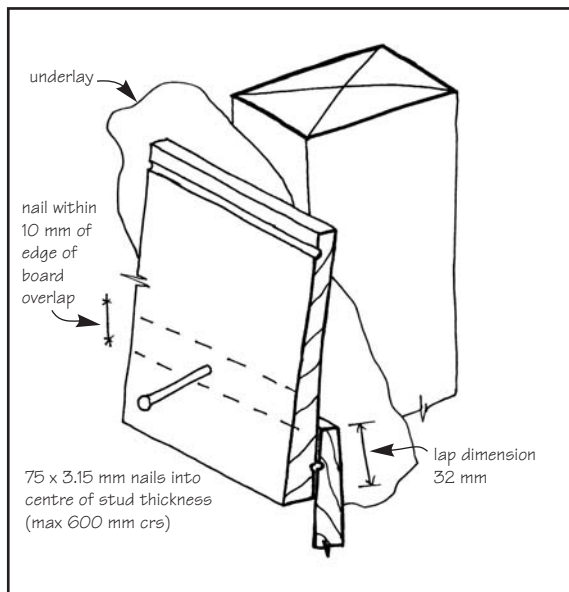

Figure 5. Splay (skew) cut boards direct-fixed (Alternative Solution profile).

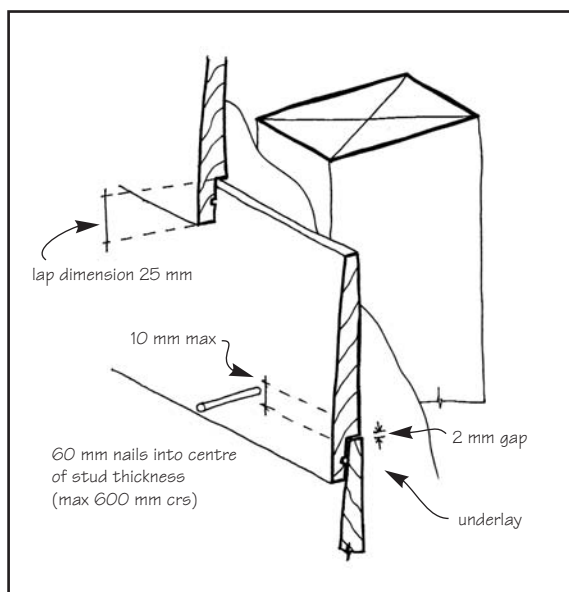

Figure 6. Rebated skew (splay) cut boards (Alternative Solution profile).

4.2.5 Table 1 gives nail sizes suitable for different board profiles.

### 4.3 Nail types

4.3.1 Nails can either be driven by hand or with a nail gun. They are selected according to:

- length
- diameter
- type of head
- type of shank
- metal used
- coatings and durability.

4.3.2 BRANZ recommends hand-driven nails for weatherboard work. Installing weatherboards is a 'finishing' operation, not a framing one, and care is required to achieve a good finished appearance. Nails need to be punched for painted boards.

4.3.3 Hand-driven nails can be 'felt' as they penetrate the timber, ensuring:

- proper contact into the framing and to the desired depth
- correct pressure contact of weatherboards against the framing.

4.3.4 Nail guns, if used, may be either compressed 'air guns' or gas-driven 'impulse guns'. Impulse guns are lighter and easier to handle, being free of trailing air hoses. Nail gun fixing does create larger depressions in the timber than hand nailing, which have to be filled.

4.3.5 If nail guns are used:

- ensure they are fitted with a plastic or rubber nose cap to avoid surface bruising of the timber
- utilise a depth adjuster for finishing nails to the desired depth or to the board surface
- ensure correct positioning of nails to enable fixings to penetrate framing.

4.3.6 Nail guns can use galvanised nails, but not all of these are hot-dipped galvanised, and may not have sufficient coating to meet the durability requirements of B2.

4.3.7 Staple fixing is not permitted.

### 4.4 Nail length

4.4.1 Nails must have a minimum penetration of 35 mm into the wall



framing unless the laminated batten option is used.

## 4.5 Type of head

4.5.1 Three common types of hand-driven nail are:

- jolt head – to be punched below the surface, with the hole stopped after priming but before the other finishing coats are applied
- flat head – sometimes used without punching for boards which are to be uncoated, clear or stain finished
- raised (or rose) head – used for boards that are uncoated or have a clear or stain finish. Heads have a raised dome top which is driven to just clear of the surface, protecting the board from hammer marks.

4.5.2 Nail gun heads are generally ‘D’ heads, although some stainless steel ‘T’ heads are available. Some round heads, such as ‘coil nails’, are available but these are not widely used. Because of the irregular shape of gun nail heads, they are often considered unsuitable for stain or natural finished weatherboarding. If ‘D’ heads are to be left exposed, care should be taken to align the heads in the same direction to achieve a consistent appearance.

## 4.6 Type of shank

4.6.1 The holding ability of a nail is dependent on the roughness of the shank, its diameter and the shape of the head.

	E2/AS1				BRANZ	
	Direct-fixed		Over cavity		Battens	Weatherboards
	Paint-finish	Stain or bare	Paint-finish	Stain or bare		
<b>Horizontal bevel-back</b>	75 x 3.15 jh galv* nails or 65 x 3.15 jh galv* annular groove nails	65 x 3.2 rh galv* annular grooved nails	90 x 4.0 jh galv* nails or 75 x 3.15 galv* annular grooved nails	85 x 3.2 rh galv* annular grooved nails	60 x 2.8 jh or fh galv* or 75 x 3.15 jh or fh galv* or 64 x 2.8 jh or fh galv*	75 x 3.15 jh galv* nails
<b>Horizontal rebated bevel-back</b>	75 x 3.15 jh galv* nails or 65 x 3.15 jh galv* annular groove nails	50 x 3.2 rh galv* annular grooved nails	75 x 3.15 jh galv*	70 x 3.2 rh galv* annular grooved nails	60 x 2.8 jh or fh galv* or 75 x 3.15 jh or fh galv* or 64 x 2.8 jh or fh galv*	75 x 3.15 jh galv* nails
<b>Horizontal rusticated</b>	60 x 2.8 jh galv* nails or 50 x 2.8 jh galv* annular groove nails	50 x 3.2 rh galv* nails	75 x 3.15 jh galv* nails	70 x 3.2 rh galv* nails	60 x 2.8 jh or fh galv* or 64 x 2.8 jh or fh galv*	60 x 2.8 jh galv* nails
<b>Vertical shiplap</b>	60 x 2.8 jh galv* nails or 50 x 2.8 jh galv* annular groove nails	50 x 3.2 rh galv* nails	n.a.	n.a.	n.a.	n.a.
<b>Board and batten: board</b>	60 x 2.8 jh galv* nails	60 x 3.2 rh galv* nails	n.a.	n.a.	n.a.	n.a.
<b>Board and batten: batten</b>	75 x 3.2 rh galv* nails	75 x 3.2 rh galv* annular grooved nails	n.a.	n.a.	n.a.	n.a.
<b>NOT IN E2/AS1</b>						
<b>Splay cut</b>	75 x 3.15 jh galv* nails or 65 x 3.15 jh galv* annular groove nails	65 x 3.2 rh galv* annular grooved nails	90 x 4.0 jh galv* nails or 75 x 3.15 galv* annular grooved nails	85 x 3.2 rh galv* annular grooved nails	60 x 2.8 jh or fh galv* or 75 x 3.15 jh or fh galv* or 64 x 2.8 jh or fh galv*	75 x 3.15 jh galv* nails
<b>Rebated splay cut</b>	60 x 2.8 jh galv* nails or 50 x 2.8 jh galv* annular groove nails	50 x 2.8 rh galv* nails	75 x 3.15 jh galv* nails	70 x 3.2 rh galv* nails	60 x 2.8 jh or fh galv* or 64 x 2.8 jh or fh galv*	60 x 2.8 jh galv* nails
<b>LEGEND:</b>	jh jolt head   rh rose head   fh flat head					
<b>NOTES:</b>	Use galv* hot-dip galvanised nails, except where the cladding is corrosive timber, such as western red cedar or redwood, use: <ul style="list-style-type: none"> <li>• stainless steel nails – which are required to have annular grooves to provide similar withdrawal resistance to hot-dipped galvanised nails</li> <li>• silicon bronze nails</li> <li>• aluminium nails.</li> </ul>					

4.6.2 Hot-dip galvanised nails have better holding power with their rougher surface than plain bright shanks for a given diameter.

4.6.3 Annular groove or twist shank nails are deliberately shaped to promote holding ability.

4.6.4 For nails of the same length, diameter and head size, annular grooved hot-dip galvanised nails have approximately three times the holding power of plain bright steel nails in radiata pine.

#### 4.7 Metal used for nails

4.7.1 Hot-dip galvanised nails are widely used because of their resistance to corrosion for most situations, and their relatively low cost compared with other corrosion-resistant metals.

4.7.2 Hot-dip galvanised steel nails must be paint protected in corrosion zone 1, sea spray and geothermal zones (refer to maps in NZS 3604).

4.7.3 There is a wide variability in 'galvanised coatings', and a minimum thickness/coating weight is not specified for nails in the NZBC or NZS 3604.

4.7.4 To achieve 15-year durability, BRANZ recommends that galvanised fixings for H3.1-treated weatherboard cladding with a three-coat system (as per NZS 3604 Table 4.3, footnote 3), have a coating mass of at least:

- seaspray and corrosion zone 1  
300 g/m<sup>2</sup>
- corrosion zones 2, 3 and 4  
275 g/m<sup>2</sup>.

4.7.5 To achieve 15-year durability, BRANZ recommends for unpainted exterior cladding (radiata pine H3.1) to have a coating mass of at least:

- sea spray and corrosion zone 1  
400 g/m<sup>2</sup>
- corrosion zones 2, 3 and 4  
300 g/m<sup>2</sup>.

4.7.6 Stainless steel, copper and silicon bronze are recommended for unpainted and stained cladding of cedar, redwood and cypress species (macrocarpa), as galvanised steel should not be used with these. The choice between stainless steel, cop-

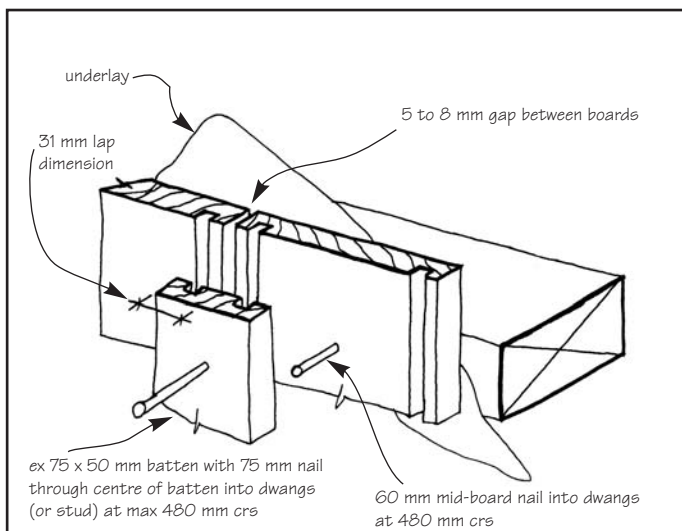

Figure 7. Vertical board and batten.

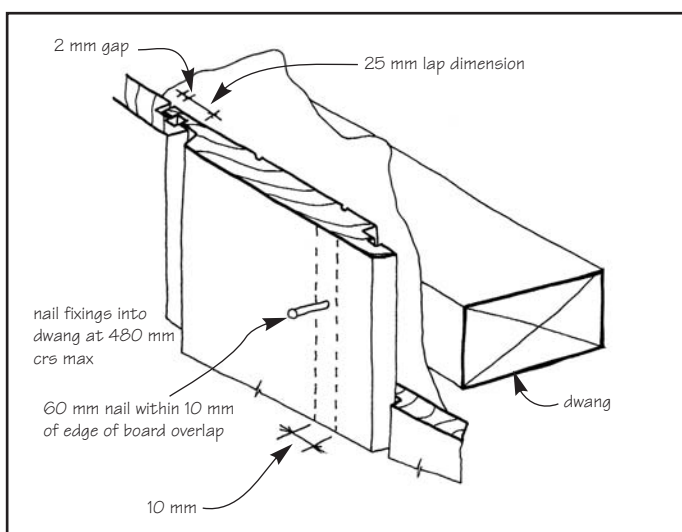

Figure 8. Shiplap boards.

per or silicon bronze usually depends on price. However, copper nails can cause staining of the weatherboard surface.

4.7.7 Aluminium nails are rather soft and can bend if they strike a knot, but newer hardened aluminium nails are now available. Aluminium nails must not be used in unpainted copper-based treated timber, as a combination of moisture (above 20%) and copper salts will corrode the aluminium.

4.7.8 Plain bright mild steel nails are not recommended. Over time, even when used behind paint finishes, these nails corrode and cause deterioration of the surrounding timber and discolouring of the painted weatherboard surface.

4.7.9 Zinc electroplated nails do not have sufficient protection against corrosion and are not recommended for weatherboard fixing.

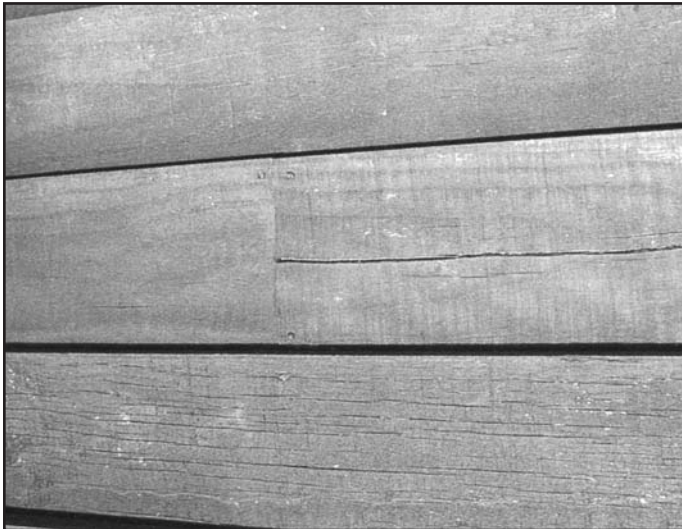

*Splitting of boards as a result of double nailing.*



*Consequences of rusticated weatherboards that were installed without an expansion gap. (Note the incorrect double nailing.)*

## MISSION

To provide innovative and creative solutions to the industry by means of research, testing, consulting and information transfer.

### HEAD OFFICE AND RESEARCH STATION

Moonshine Road, Judgeford  
Postal Address – Private Bag 50 908, Porirua City, New Zealand.  
Telephone – (04) 237 1170, Fax – (04) 237 1171  
<http://www.branz.co.nz>

### AUSTRALIAN OFFICE

#### SYDNEY

Telephone – (00612) 9938 6011  
Fax – (00612) 9938 6911  
Unit 3/20 West Street, Brookvale, NSW 2100, Australia  
PO Box 830, Brookvale, NSW 2100, Australia



**BRANZ ADVISORY HELPLINES**  
*For the building and construction industry*  
**0800 80 80 85**  
▲ ▲ ▲ ▲ ▲ ▲  
*For the home owner and public enquiries*  
**0900 5 90 90**  
Calls cost \$1.99 per minute plus GST. Children please ask your parents first

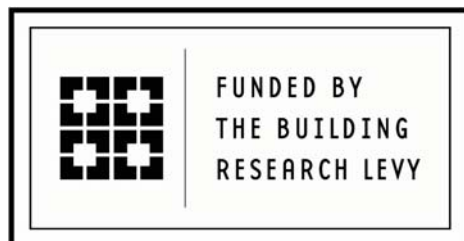

Standards referred to in this publication can be purchased from Standards New Zealand by phoning 04 498 5991 or by visiting the website: [www.standards.co.nz](http://www.standards.co.nz).

Please note, BRANZ books or bulletins mentioned in this publication may be withdrawn at any time. For more information and an up-to-date list, visit BRANZBookshop online: [www.branz.co.nz](http://www.branz.co.nz) or phone BRANZ 0800 80 80 85, press 2.

DISCLAIMER: The information contained within this publication is of a general nature only. BRANZ does not accept any responsibility or liability for any direct, indirect, incidental, consequential, special, exemplary or punitive damage, or for any loss of profit, income or any intangible losses, or any claims, costs, expenses, or damage, whether in contract, tort (including negligence), equity or otherwise, arising directly or indirectly from or connected with your use of this publication, or your reliance on information contained in this publication.

ISSN 1170-8395

Copyright © BRANZ 2005. No part of this publication may be photocopied or otherwise reproduced without the prior permission in writing from BRANZ.

---