

# BULLETIN

ISSUE 536



## UPGRADING PILED FOUNDATIONS TO RESIST EARTHQUAKES

June 2011

Older houses with piled foundations without subfloor bracing can be particularly vulnerable to damage in earthquakes.

This *Bulletin* discusses options for upgrading the foundations to reduce the risks of earthquake damage.

This *Bulletin* does not deal with foundation damage resulting from liquefaction.

## 1.0 INTRODUCTION

**1.0.1** Earthquakes are caused by the breaking and shifting of rock beneath the earth's surface at the boundary of the Pacific and the Australian plates. This activity can cause ruptures to occur on the fault lines that tend to run North-South through the Southern Alps and then through Wellington, the Hawkes Bay and Bay of Plenty. However, some recent earthquakes have taken place on faults where the precise location of the fault was not well known. No area in New Zealand is totally immune to earthquakes.

**1.0.2** Faultline ruptures can cause violent movement of the earth's crust in all directions. Not only can the ground move violently sideways but it can also move vertically. People who experienced the 2010/2011 earthquakes in Canterbury have described the difficulty they had in standing up against the violent movement both sideways and up and down.

**1.0.3** The effects on houses and their contents can be wide and varied, depending on factors such as ground conditions, age, quality of construction and subsequent maintenance, plan configuration, and whether contents are secured. The damage sustained is generally due to the inability of the superstructure of the house to move (particularly sideways) as quickly as the ground beneath it does, because it is too slow to respond.

**1.0.4** Very stiff houses will move in time with the ground, but the contents are likely to be subjected to violent motions. More flexible houses, like the common timber framed house, are expected to deform in a major earthquake.

**1.0.5** There are several measures that can be taken at subfloor level to reduce the risk of damage. This bulletin discusses these measures, including new or replacement pile connections, bracing of piles and jack studs, perimeter sheet bracing and connections to floors.

**1.0.6** Determine typical pile depth before starting work. Wherever appropriate, refer to NZS 3604 Timber Framed Buildings.

## 2.0 PILE CONNECTIONS

**2.0.1** Many houses are built on pile foundations which, if built since 1930, are likely to be concrete or treated timber. Adequate connection between piles and bearers (supporting the floor joists) is critical to ensure that in an earthquake the house does not fall off the piles, causing the piles to punch through the floor.

**2.0.2** These pile/bearer connections should be either a piece of 4 mm diameter galvanised wire fixed to the pile and the bearer with staples or Z nails (wire dogs) and skewed nails (Figure 1). If the house is more than 30 years old, or has damp, poorly ventilated subfloor space, these fixings may have rusted badly or rusted away and will need replacing.

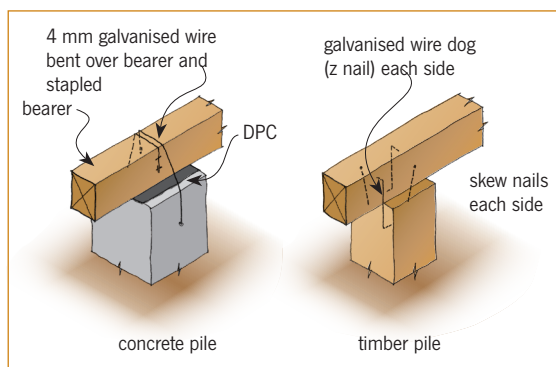

Figure 1. Typical modern pile to bearer connections

**2.0.3** There are proprietary fixings available to retrofit to existing timber piles, or new galvanised wires, appropriately stapled to the bearers, can be fixed to disconnected concrete piles.

## 3.0 SUBFLOOR BRACING

### 3.1 HOUSES WITH CONCRETE PERIMETER WALLS OR CORNER WALLS

**3.1.1** Under severe earthquake loading, especially if the piles are tall, the piles may tilt over if they are not braced in some fashion, or built very close to the ground (a maximum 200 mm to the underside of the bearers).

**3.1.2** A house with a concrete perimeter foundation wall is probably sufficiently braced. In this case, re-fixing the bearers to the piles will not be critical (but still a good idea). However, the wall plate should be fixed to the foundation wall to resist sliding.

**3.1.3** Even sections of concrete foundation wall at the corners provide sufficient bracing, unless the corner walls are taller than they are long, causing them to rotate over during an earthquake. In this case, either add sheet bracing as shown in Figure 2, or diagonal timber braces, as shown in Figure 3.

**3.1.4** In corner wall construction (see Figure 4), the floor joists may not be adequately connected to the foundation wall. In this case, bolt a diagonal timber brace to both the joist and the concrete wall (as shown in Figure 4). This must be done at both ends of the house to distribute earthquake loads between all available walls.

### 3.2 HOUSES WITHOUT CONCRETE PERIMETER WALLS OR CORNER WALLS

**3.2.1** Houses built since 1980 may have braced piles, or piles deeply buried in the soil ('anchor' piles), to prevent tipping in an earthquake. If you are uncertain about the situation with a particular house, engineering advice may be necessary.

**3.2.2** Some piled houses have no perimeter foundation walls, only horizontal boards, with gaps between them, fastened to the perimeter piles. These boards provide no bracing resistance. There are two options for remediation.

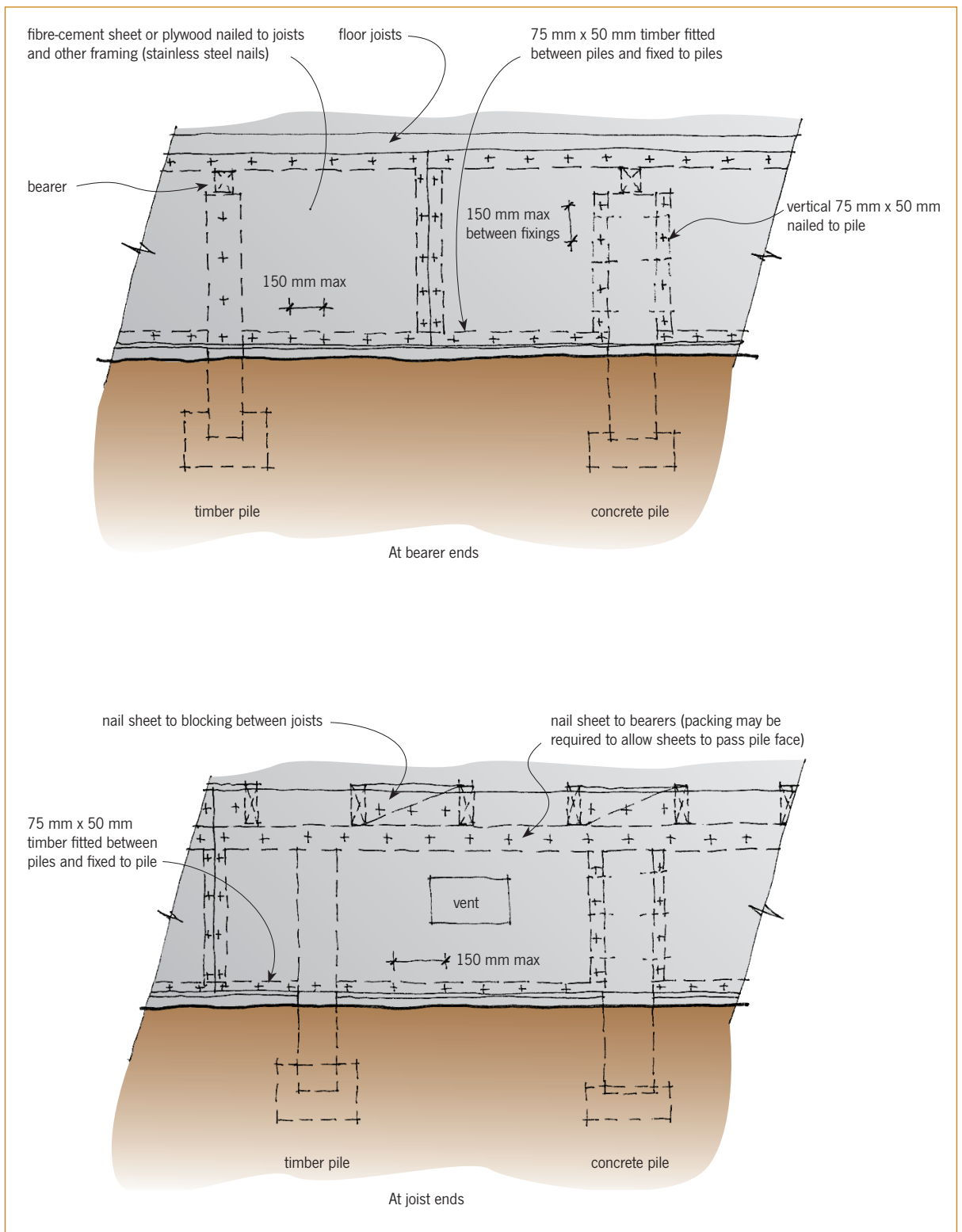

Figure 2. Bracing piled house with sheet material

**3.2.3 Sheet bracing** (timber or concrete piles). This option applies to piles where there is greater than 600 mm between the ground level and the underside of the joists. Remove the horizontal boards and replace with either 7.5 mm fibre-cement sheet (if painted, especially on the bottom edge) or 12 mm exterior grade plywood sheet bracing. The top must be fixed to the boundary joist or the bearer, as appropriate, which may require some well-nailed packing to bring it out to the face of the piles. When the top is fixed to the bearer, carry the sheet up and fix to blocking between the joists above as well, if possible. Fix in accordance

with the manufacturer's specification for subfloor braced panels. (If the house has all shallow piles, with less than 600 mm between the ground level and the underside of the joists, get specialist advice.)

**3.2.4** Timber piles will require extra framing timber between them (treated to H1.2 boric) to support the bottom edge of the sheet material. With concrete piles, timber framing is needed, fixed to the piles with concrete nails or shot fired pins to take the sheet bracing (Figure 2).

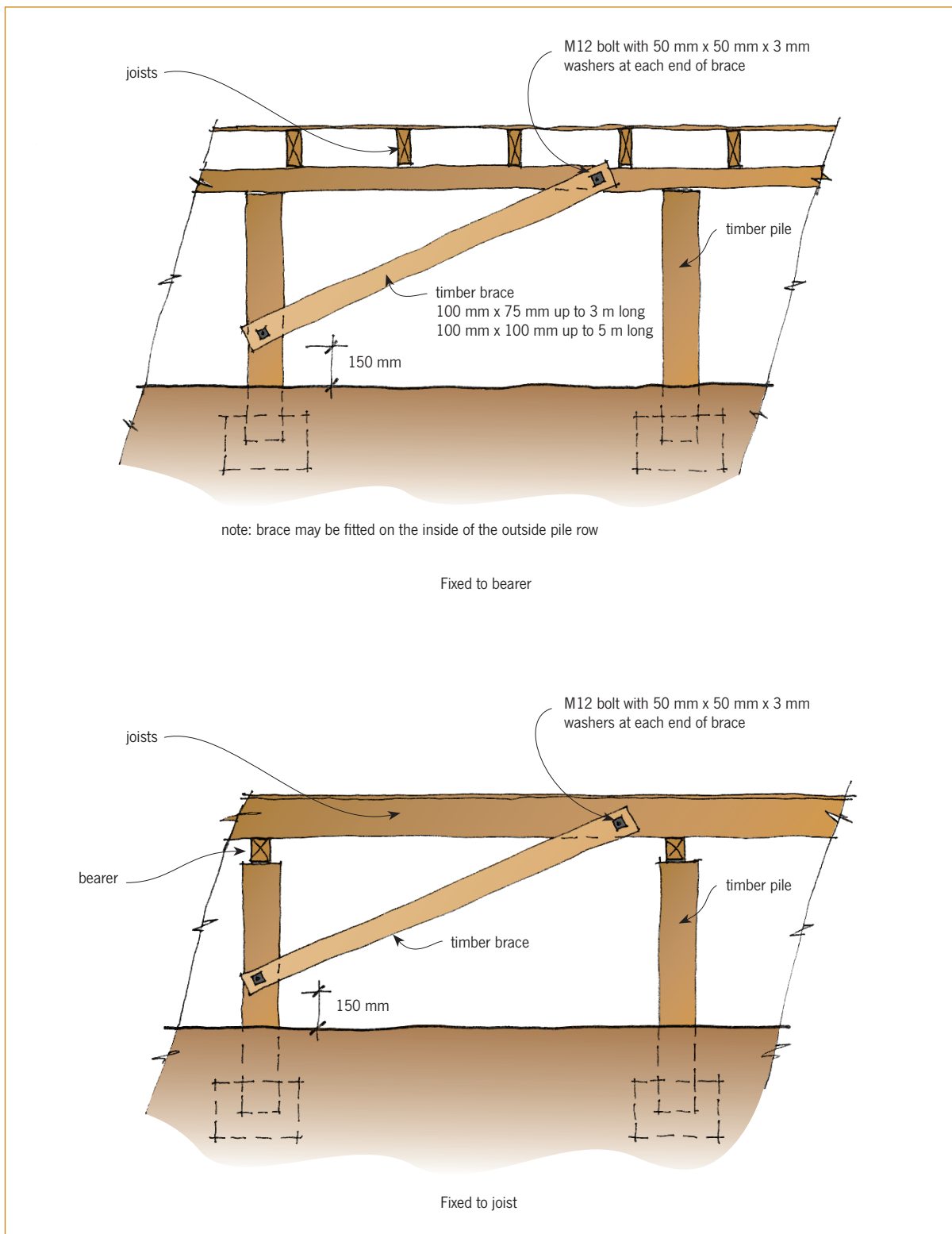

Figure 3. Added timber braces to timber piles

**3.2.5** Subfloor ventilation is required to prevent dampness in the subfloor space. This can be provided by ventilation grilles giving a clear opening area of 3500 mm<sup>2</sup> (say 100 mm by 35 mm) per m<sup>2</sup> of the floor area, evenly distributed around the perimeter.

**3.2.6 Diagonal bracing** (timber piled foundations only). Houses supported on timber piles not set deep enough into the ground (450 mm) to prevent tilting may be braced with diagonal timber braces. These may be placed between a pile and a bearer, or between a pile and a joist (the preferred option,

because the brace is more directly fixed to the floor plane) (Figure 3).

1. Add at least two braces on the outside row and every second row in both directions.
2. The bolt connecting the brace to the bottom of the pile must be an M12 at 200-300 mm above ground.
3. The top bolts should be at least hot-dipped galvanised steel, the bottom ones stainless steel.
4. The slope angle of the brace should be no steeper than 45° (Figure 4).

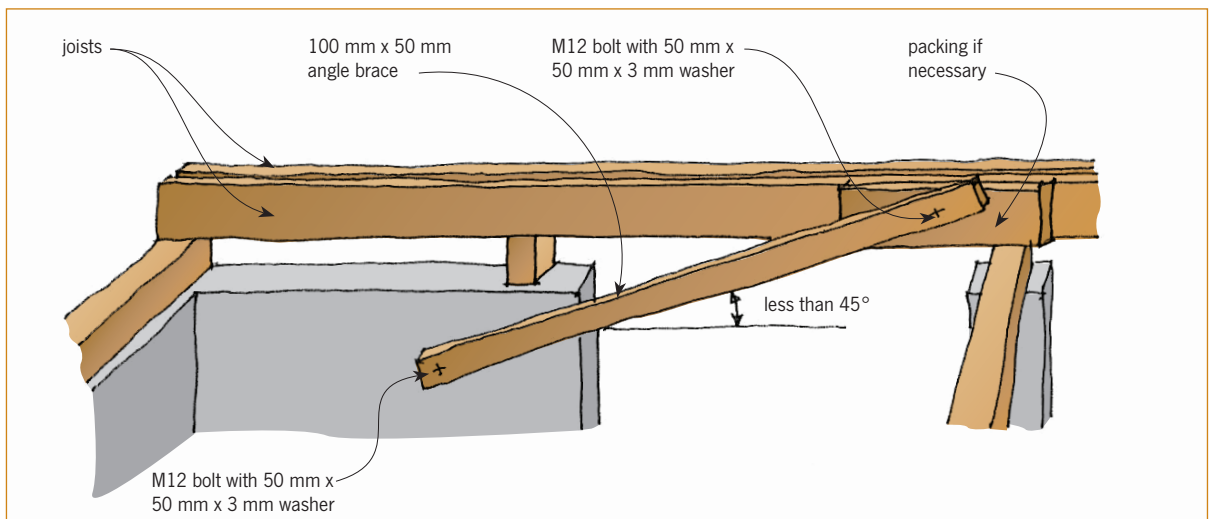

Figure 4. Corner wall to joist remedial connection

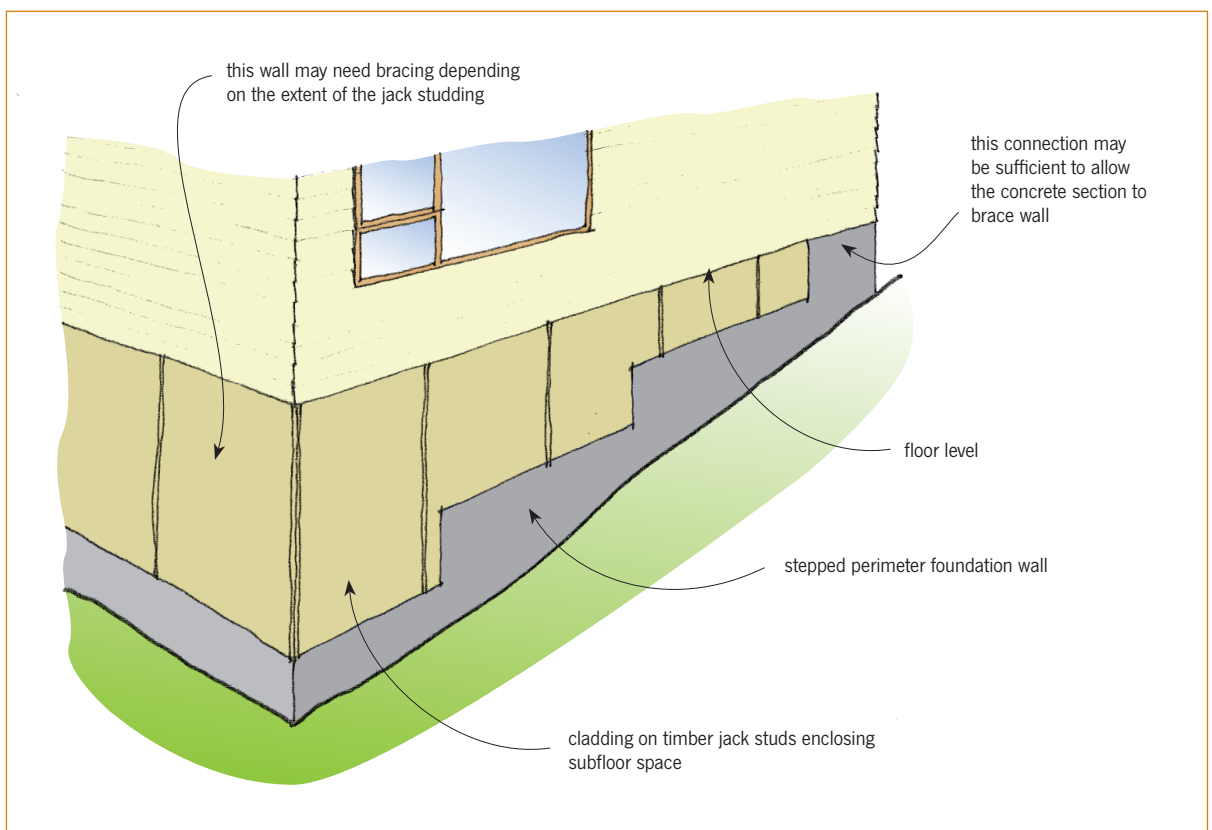

Figure 5. Framed perimeter foundation walls

## 4.0 TIMBER JACK STUD SUBFLOOR FRAMING

**4.0.1** Some houses built on sloping sites have timber jack studs between foundation walls or piles and the floor framing (Figure 5). The main function of jack studs is to hold the house up, but they can be quite vulnerable to sideways loading.

**4.0.2** In Figure 7, if the section of concrete wall at the right hand end is connected directly and

adequately to the floor (M12 bolts or bent over rebar at the ends and at less than 1m centres in between), then extra bracing along this wall may not be needed. If the wall on the left hand side in the drawing has jack studs over its whole length then extra bracing may be needed. This can be provided by diagonal timber braces fixed to the inside face of the wall, or by sheet bracing (as in 5.0.3 below).

**4.0.3** The sheet cladding on the outside of the framed foundation wall in houses built before 1985 may be brittle or damaged, and unable to provide bracing resistance.

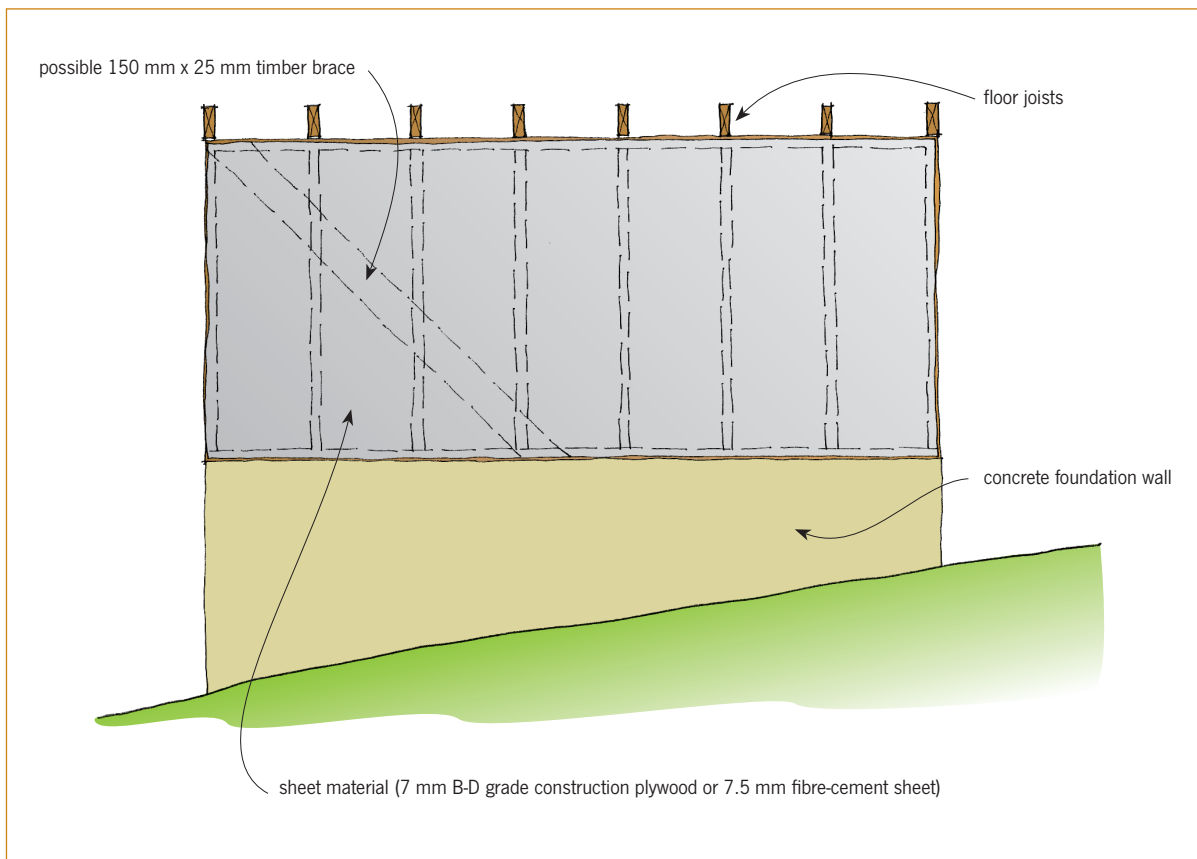

Figure 6. System for strengthening jack-framed foundation walls against earthquakes

#### 4.0.4 The alternatives (Figure 6) are to:

1. Replace existing cladding with 7.5 mm minimum new fibre-cement sheet nailed at 150 mm centres to the timber plates and studs around the perimeter of all sheets with 40 x 2.5 galvanised flat head nails, and to intermediate studs with nails at 300 mm centres (nailing is important).
2. Install 50 x 25 mm diagonal timber bracing to the inside face of the framing.

4.0.5 For jack stud framing over shallow piles, obtain specific engineering advice.

## 5.0 HOUSES WITH LARGE OPEN SPACES BENEATH THEM

5.0.1 Some houses, because of sloping ground or a split level, have a large open area supported by posts and beams providing parking underneath (Figure 7), and this area may not be sufficiently braced.

5.0.2 In an earthquake, without proper bracing, the taller end of the house will move more than the lower end, which twists the house, causing instability and possible collapse. This is more critical in split level houses where the upper storey floor is disconnected from the lower single storey floor.

5.0.3 To prevent this, it may be necessary to close in one of the openings with a new wall to provide the required bracing. Engineering advice is recommended in such situations. If three sides are able to provide some bracing, then a diaphragm above will provide extra bracing. This would involve either:

1. lifting the floor coverings above and adding fixings to the sheet flooring, or
2. adding a plywood or plasterboard ceiling lining beneath the floor over the open area.

5.0.4 Edge dwangs between floor joists may be needed before the sheets are nailed to the framing at 150 mm centres around the perimeter of the sheets. However, connections between the floor or the ceiling and the perimeter walls would need to be adequate to transfer the earthquake forces between the two. Engineering advice is recommended in such a situation.

## 6.0 FURTHER READING

#### 6.0.1 Publications:

- BRANZ *Build* 121: *Strengthening Piled Foundations*

#### 6.0.2 Useful websites:

- [www.dbh.govt.nz/guidance-on-repairs-after-earthquake](http://www.dbh.govt.nz/guidance-on-repairs-after-earthquake)

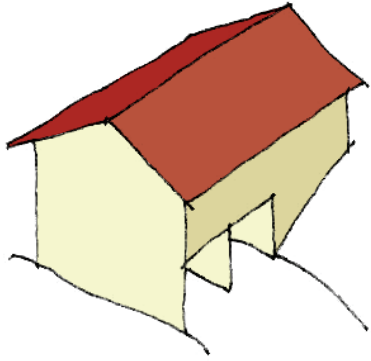

house type: single level, side access

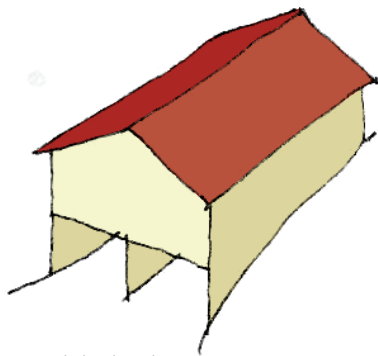

house type: single level, end access

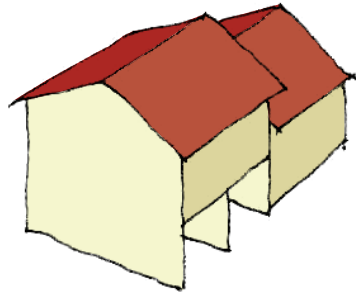

house type: split level, side access

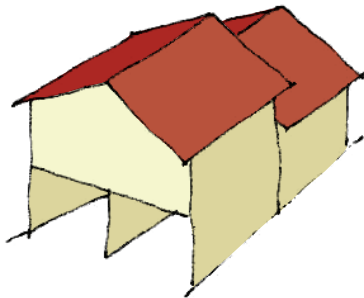

house type: split level, end access

Figure 7. Variations on houses with large open spaces underneath

**THE CORE PURPOSE OF BRANZ IS TO IMPROVE PEOPLE'S LIVES THROUGH OUR RESEARCH AND OUR DRIVE TO INFORM, EDUCATE AND MOTIVATE THOSE WHO SHAPE THE BUILT ENVIRONMENT.**

**BRANZ ADVISORY HELP LINES**

FOR THE BUILDING INDUSTRY

**0800 80 80 85**

FOR THE HOME OWNER AND PUBLIC ENQUIRIES

**0900 5 90 90**

Calls cost \$1.99 per minute plus GST. Children please ask your parents first.

HEAD OFFICE AND RESEARCH STATION

Moonshine Road, Judgeford  
Postal Address – Private Bag 50 908, Porirua City 6220,  
New Zealand  
Telephone – (04) 237 1170, Fax – (04) 237 1171  
<http://www.branz.co.nz>

Standards referred to in this publication can be purchased from Standards New Zealand by phone 04 498 5991 or by visiting the website: [www.standards.co.nz](http://www.standards.co.nz).

Please note, BRANZ books or bulletins mentioned in this publication may be withdrawn at any time. For more information and an up-to-date list, visit BRANZ Shop online: [www.branz.co.nz](http://www.branz.co.nz) or phone BRANZ 0800 80 80 85, press 2.

Disclaimer: The information contained within this publication is of a general nature only. BRANZ does not accept any responsibility or liability for any direct, indirect, incidental, consequential, special, exemplary or punitive damage, or for any loss of profit, income or any intangible losses, or any claims, costs, expenses, or damage, whether in contract, tort (including negligence), equality or otherwise, arising directly or indirectly from or connected with your use of this publication, or your reliance on information contained in this publication.

ISSN 1170-8395

Copyright © BRANZ 2011. No part of this publication may be photocopied or otherwise reproduced without the prior permission in writing from BRANZ.