

ISSUE 662 **BULLETIN**



## UNIVERSAL DESIGN FOR ACCESS INTO HOMES

June 2021

- A universal design approach to access into homes means ensuring the main route to and into the dwelling is accessible to all.
- Steps and steep slopes along the route into a home can make it difficult for many people to enter and leave independently. Well-designed routes can make entering and leaving home easier and safer for most people.
- This bulletin provides a range of universal design considerations for ensuring the routes to new and existing homes are accessible.

## 1 INTRODUCTION

**1.0.1** The design of pedestrian access routes into the entrances of many dwellings in New Zealand often does not account for the diverse capabilities of people living in or visiting a home. Steps, steep slopes and narrow paths may restrict who can live in or visit a dwelling, as they can be difficult or impossible for many people to navigate.

**1.0.2** Accessible routes include features such as landscaping that provides a gentle slope for everyone along with ramps and handrails that can make access into homes easier for a large number of people including:

- elderly people, who may be experiencing a wide range of mobility issues or frailty
- wheelchair users, who may not be able stand or walk without assistance
- people who can walk but with difficulty (ambulant disabled people) and may use mobility aids such as sticks, crutches, artificial limbs and walking frames
- people who are blind, have low vision, are deaf or have hearing loss
- people with prams, pushchairs and/or young children
- able-bodied people with short-term disabilities or injuries or after surgery.

**1.0.3** Designing and adapting houses in a way that enables more people to live there at all stages of their life makes sound economic as well as emotional sense. It gives people independence, lessens their dependency, lowers the risk of accidents, reduces the cost to society and is likely to increase the resale value of the property.

**1.0.4** The New Zealand Building Code requires that accessible routes be provided for premises providing accommodation, such as groups of pensioner flats, rest homes, boarding houses, hostels and student halls of residence. The Building Code does not currently require accessible routes for private housing, but ensuring dwellings keep people safe and meet their needs throughout their lives makes good economic, social and business sense.

**1.0.5** Accessible dwellings have a wider range of possible purchasers and can have a higher resale value. Accessible routes also reduce the chance of accidents. They enable occupants to age in place, be more independent and remain in their own homes and communities for longer, which reduces costs to society.

**1.0.6** Accessible routes can be added to existing dwellings. This is made easier if the original design of the house anticipates and allows for later adaptations.

**1.0.7** This bulletin covers universal design considerations for outdoor pedestrian access into the main entrance of a dwelling. It does not cover access into non-residential buildings, vehicle access or internal residential access.

**1.0.8** The universal design considerations in this bulletin can contribute towards providing accessible routes into new and existing homes but cannot provide a one-size-fits-all solution for every site and situation. It is recommended that, when designing accessible routes

for dwellings, the likely needs of the occupants and people visiting are understood and considered at the same time.

## 2 GENERAL REQUIREMENTS FOR ACCESS ROUTES

**2.0.1** Building Code clause D1 *Access routes* requires safe and easy movement of people from the street boundary, protecting them from injury while moving into and out of buildings while ensuring they are safe around any visiting vehicles.

**2.0.2** Routes must be free from obstructions, and appropriate care needs to be taken around projections, such as opening windows. Some types of projection into access routes are allowed in some circumstances – see Acceptable Solution D1/AS1 clause 1.5 for details. Minimum headroom of 2,100 mm must be provided for access routes and 2,000 mm minimum for landings less than 2,000 mm in length and for any stairways.

**2.0.3** Access routes must have a safe slope in the direction of travel, an appropriate cross-fall or means of draining the surface and adequate surface slip resistance to prevent slipping under normal use and conditions.

**2.0.4** If the slope is 1:20 or less, the access is considered a walkway or footpath. If the slope of an accessible route exceeds 1:20, it must be treated as a ramp.

**2.0.5** Where ramps or stairs are provided, they must have continuous, smooth, reachable and graspable handrails to provide support and assist with movement along the route. Where there is a drop to the side of a ramp, provide a low rail or kerb. Clause F4 *Safety from falling* requires that, where there is a drop of more than 1,000 mm, an adequate barrier must be provided.

**2.0.6** In line with clause B1 *Structure*, all structures must safeguard people from injury from structural failure, be comfortable and convenient to use and be able to withstand the combination of loads that they are likely to experience while in use and during construction or alteration.

**2.0.7** Clause B2 *Durability* requires that a structure must have adequately durable materials, components and construction to allow it to meet Building Code requirements during its life.

**2.0.8** All exitways and common spaces in multi-unit dwellings and group and communal residential buildings must be adequately lit by natural or artificial light to allow safe movement under clause G8 *Artificial light*.

**2.0.9** A building consent is needed for structures where a person could fall 1,500 mm or more. Landings and ramps not needing consent must still comply with Building Code requirements. Check whether a resource consent from the council is also needed. A Code-compliant barrier will be needed for drops larger than 1,000 mm.

## 3 DESIGNING ACCESSIBLE ROUTES

**3.0.1** If a route is designed to be accessible, it must be easy to find. It should be the main route into the dwelling where possible. Using colour and other visual cues can help people with cognitive difficulties or impaired vision to find their way in.

**3.0.2** Access routes must have a minimum clear width of 1,200 mm, giving enough space for people on foot and people with walkers or other equipment to pass or to use the route together. Wider routes will provide more options for passing, and a width of 1,800 mm should be considered if appropriate.

**3.0.3** The route must not include any steps that would be a barrier to wheelchair users or people with walkers or other equipment, including at the front door. This means the change in level at the threshold at the entrance door cannot exceed 20 mm.

**3.0.4** Handrails must be provided on both sides of the route if the slope exceeds 1:20.

**3.0.5** Accessible routes with steps can be provided alongside routes without steps so that both options are available. Some people find [suitable] staircases easier to use than ramps.

**3.0.6** Any steps provided along the route must not have open risers and must have handrails on both sides. The leading edge of the stair tread must be rounded, and its colour must contrast with the rest of the tread. Avoiding single isolated steps is recommended. Accessible staircases have a maximum pitch line of 32° from horizontal, risers should be no more than 180 mm and treads no smaller than 310 mm.

**3.0.7** If the footpath or ramp is more than 25 mm off the ground, provide low edge rails or kerbs of 75 mm minimum height to prevent wheelchairs, pushchairs and prams from running off the edge of the route.

**3.0.8** Further detail is provided below and in Acceptable Solution D1/AS1 and NZS 4121:2001 *Design for access and mobility: Buildings and associated facilities*.

### 3.1 RAMPS

**3.1.1** Ramps can provide access where there is a change of level.

**3.1.2** The form of the ramp and any landings will depend on the total rise required and the direction of fall of the ground [Figure 1].

**3.1.3** The design of the ramp should be predictable. Transitions between ramps and landings should be smooth but visible. If multiple ramps are used in one route, their slope should be identical.

**3.1.4** Avoid building curved ramps. Wheelchair users, people with prams and pushchairs and people with walking aids can find these difficult to use. Changes in direction must occur at level landings, not mid-ramp.

**3.1.5** Where a ramp is required, use the space available to lower the gradient as much as possible. Although the maximum gradient for accessible ramps is 1:12, this slope may still be too steep for wheelchair users and for some people on foot. The preferred slope range for ramps is between 1:16 and 1:20.

**3.1.6** If the surface is likely to become wet, a cross-fall for footpaths and ramps must be a minimum of 1:100 and away from the building, unless the surface materials are designed to drain water such as timber decking or tiles with 5 mm gaps [Acceptable Solution D1/AS1]. The cross-fall must not be steeper than 1:50.

**3.1.7** Ensure that doors and windows that open near ramps will not cause obstructions or hazards. Make sure that ramps do not project into other circulation space and cause a trip hazard.

**3.1.8** Ramps should be at least 1,200 mm wide.

**3.1.9** Service ramps, where present [for example, in medium-density housing or apartment blocks], can be used in an emergency but are not suitable for general access. Ensure these are not mistaken for an access route.

### 3.2 LANDINGS

**3.2.1** Landings are important because they provide a place to pause or rest for people who find using the ramp difficult or strenuous. They should be level and provided at each end of the ramp. Where ramps or stairs approach a front entrance, an appropriately sized landing must be provided at the door.

**3.2.2** The width of the landing should not be less than the ramp it serves.

**3.2.3** The maximum rise between landings should be 750 mm. Acceptable Solution D1/AS1 recommends that this is the reasonable maximum rise in height for wheelchair users to negotiate between landings.

**3.2.4** Landings should be 1,200 mm minimum length at the foot of a ramp or between ramps. The landing size by entranceways depends on the positioning of the door and should be 2,000 mm long if the door opens outwards [Figure 2]. If the door opens outwards, the landing must include a minimum 1,200 mm length between the swing of the door and the start of the ramp. The door opening should be at least 760 mm wide when the door is open.

### 3.3 TRANSITIONS

**3.3.1** Changes in slope can create a risk for stumbling if people miss the transition between level and sloping surfaces.

**3.3.2** Ensure that the start or end of the ramp can be easily distinguished from the landings. This can be achieved by using contrasting finishes in the landing and ramp and/or changes in the lighting. If different adjacent surfaces are used, ensure that changes in finish do not result in significant changes in the surface slip resistance, as this can also cause people to stumble.

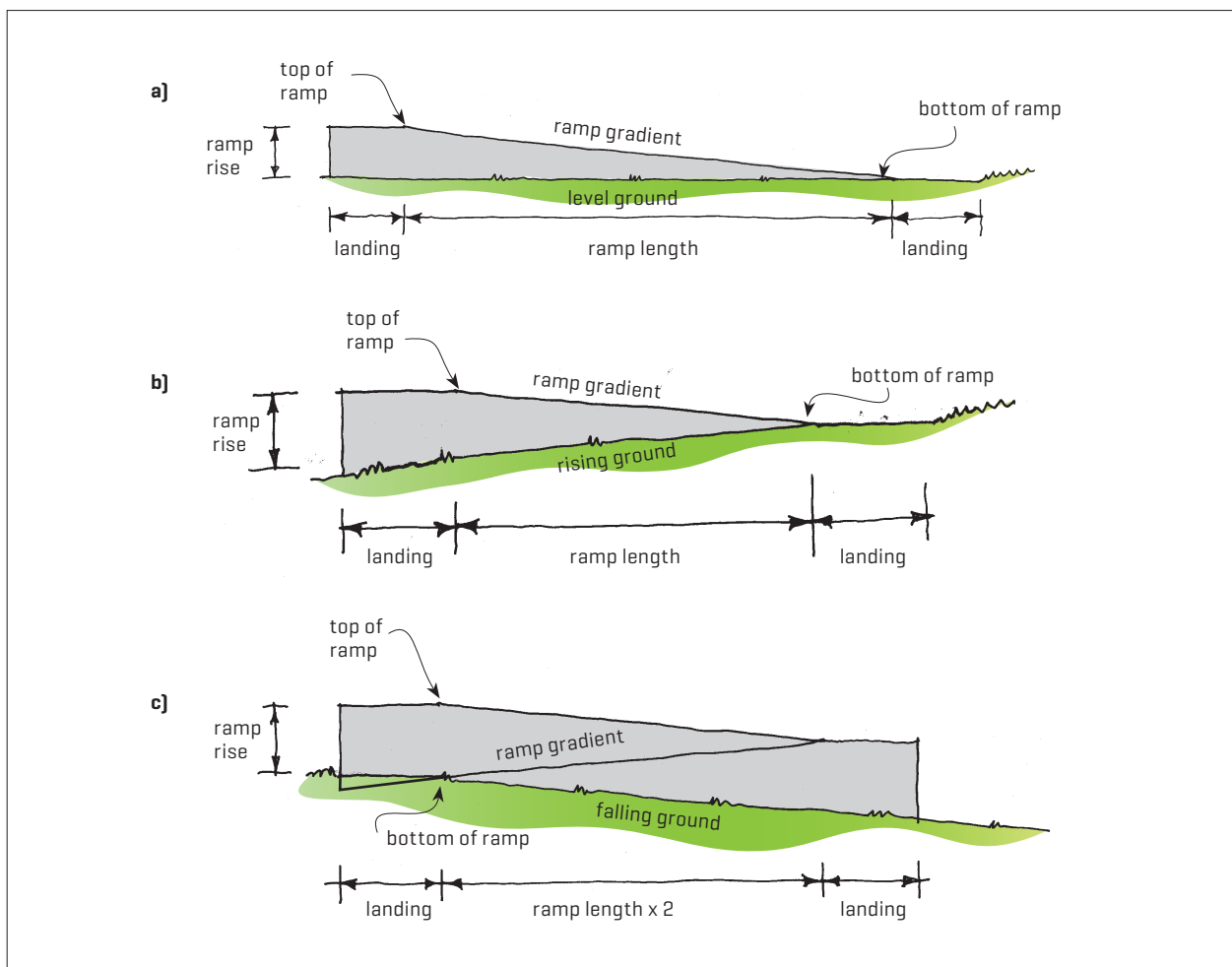

Figure 1. [a] A ramp on level ground. [b] A ramp on rising ground will be shorter. [c] A ramp on falling ground may never reach the ground unless it is turned back into the slope. [Handrails and barriers are not shown.]

**3.3.3** Use flush jointing to ensure the transition from the ramp to each landing and/or the footpath is smooth [Figure 3].

**3.3.4** Ensure that the start or end of the ramp is clearly visible. This can be achieved by using contrasting finishes on landings and ramps.

### 3.4 SLIP-RESISTANT SURFACES

**3.4.1** Surfaces leading to the main entrance of dwellings are considered public access routes under Acceptable Solution D1/AS1 and must be slip resistant under conditions of normal use.

**3.4.2** Surface materials must have a slip resistance suitable for their gradient and likely conditions under normal use. Even if a surface is under cover, it can become wet if water is tracked in during use.

**3.4.3** Table 2 of Acceptable Solution D1/AS1 gives a list of surfaces with acceptable wet slip resistance for level and sloping surfaces in wet and dry conditions. Some common flooring materials such as broomed concrete or concrete with an exposed crushed aggregate finish meet the slip resistance requirements for all conditions. Other commonly used external flooring materials such

as decking timber, tiles and pavers [depending on their finish] and concrete with an exposed rounded aggregate finish may not be suitable or may need further slip resistance testing. Timber surfaces can be made more slip resistant with sand/grit-impregnated coatings. See AS 4586-2013 *Slip resistance classification of new pedestrian surface materials* Appendices A and B for more about testing surfaces for slip resistance and Appendix F for requirements for slip resistance for different slopes.

**3.4.4** The surface of the access route must be maintained and cleaned to prevent mould and lichen growth, which will reduce slip resistance. Most ramps [unless they have built-in heating elements] are dangerous in frost or snow.

**3.4.5** Joints in bricks and paving joints and at changes in slopes must be flush. All uneven areas or badly cracked sections of existing footpaths should be replaced.

### 3.5 HANDRAILS

**3.5.1** In an accessible route, handrails must be provided on both sides of the route if the slope exceeds 1:20. They support users who have a weakness on one side or the other and assist wheelchair users who may use handrails to pull themselves up challenging gradients.

**Figure 9: Accessible Ramps**  
 Paragraphs 3.1.3, 3.3.1, 3.3.3, 6.0.3, 6.0.4 and 7.0.2

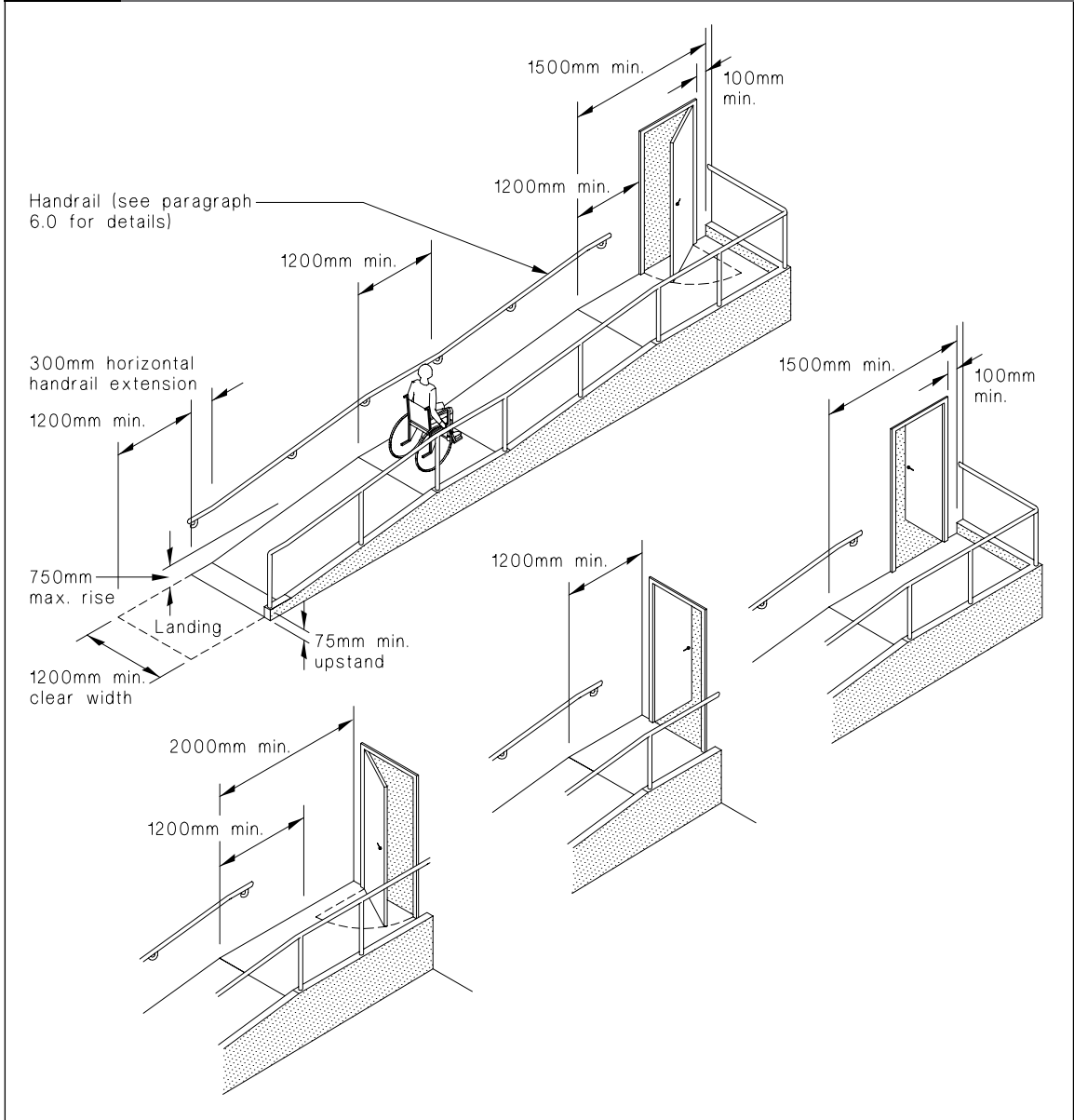

Figure 2. Acceptable Solution D1/AS1 shows the required configuration for landings. The maximum rise between landings should be 750 mm, they should not be narrower than the ramp they serve and their length at the entranceway depends on the position of the door and whether it opens inwards or outwards. © The Crown.

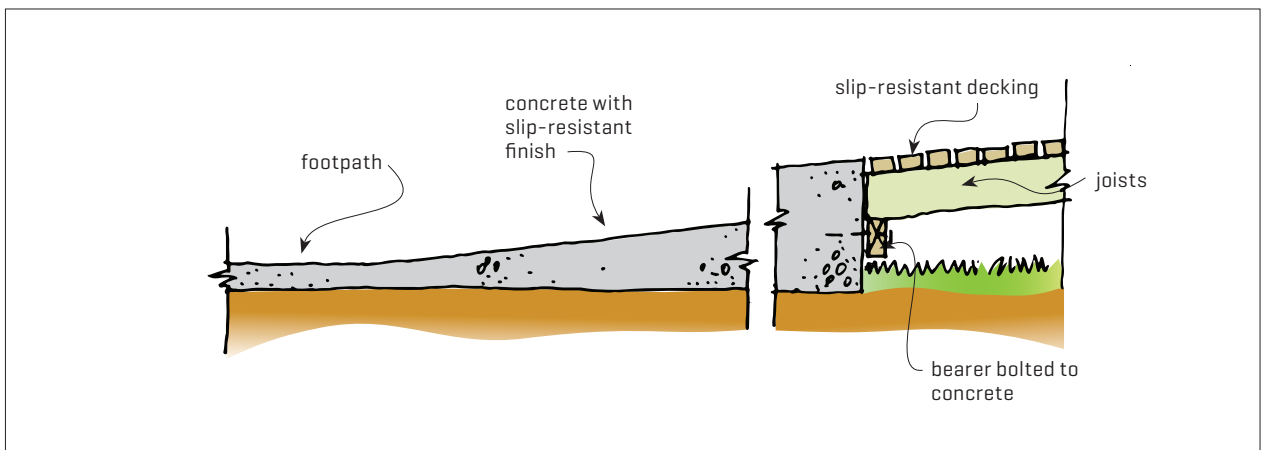

Figure 3. Concrete detailing ensures a smooth transition between the end of a timber ramp and the footpath.

**3.5.2** Handrails are optional for walkways with slopes less than 1:20. Providing handrails helps people who are not steady on their feet.

**3.5.3** Handrails must be continuous including across landings and around changes in direction except where the route is interrupted by a doorway or is joined by another route.

**3.5.4** Handrails should be:

- graspable and continuous with no obstructions where they are attached to a wall or posts
- easy to grip by an adult
- non-slip with no sharp edges (including at the ends)
- comfortable to lean on
- colour contrasting against the background so they can be identified easily by people with all levels of sight
- turned down at the ends so they do not create a hazard.

**3.5.5** The fixings should not prevent continuous holding along the route. Under normal use, the user's hand should not touch any adjacent wall or supporting brackets or fixings.

**3.5.6** Handrails and fixings must be secure and strong enough to support users. They may experience significant forces if someone stumbles or falls and uses them to pull themselves upright.

**3.5.7** Handrails must be parallel with the surface in ramps and landings or the same slope as the pitch line in stairs and within reach of all users. Consider whether a double rail is needed with a lower mid-rail at a height suitable for short people or children [Figure 4]. The top of the upper handrail must be 840–900 mm above the surface [NZS 4121:2001 section 6.4.2.6].

**3.5.8** A minimum horizontal extension should be added to the end of handrails on accessible routes. Extending the handrails horizontally beyond the end of the ramp helps with getting on and off the ramp and also gives a visual cue that the start or end of the ramp is there. If handrails stop suddenly without warning, people can stumble and fall. Domed buttons can be installed towards the end of

ramps to give warning to people navigating partly or fully by touch that the ramp is coming to an end.

**3.5.9** Ensure the end of the handrail will not catch on clothing – for example by turning the end of it downwards or towards the adjacent wall, if applicable. Children can be injured by running into the ends of handrails that are not turned down.

**3.5.10** Make sure that handrails are protected by adjacent walls and upstands and do not project into circulation space.

**3.5.11** The recommended minimum width between handrails on a stairway designed to be accessible is 900 mm.

**3.5.12** If the drop from a ramp or deck is 1,000 mm or more, a Code-compliant barrier must be provided [Figure 5]. See Acceptable Solution F4/AS1 Figures 1 and 2 for specific requirements and options.

**3.5.13** Make sure the space underneath ramps is enclosed or protected, as people who are distracted or have a visual impairment may bump into the underside and risk injuring themselves.

## 3.6 EDGE RAILS AND KERBS

**3.6.1** If there is a drop to the side of the ramp, provide an edge rail or upstand kerb at least 75 mm high to give a sense of security and to prevent wheelchair, pram or pushchair wheels from running off the edge.

**3.6.2** Upstands also help blind people or people with low vision who use a cane to find the edge of the route and ramps and landings.

## 4 LIGHTING

**4.0.1** Ensure the access route is well lit during all times it is in use. Poor visibility around changes in slope can increase the chance of stumbling, trips and falls. Artificial illumination should allow users to tell the difference between ramps and landing areas.

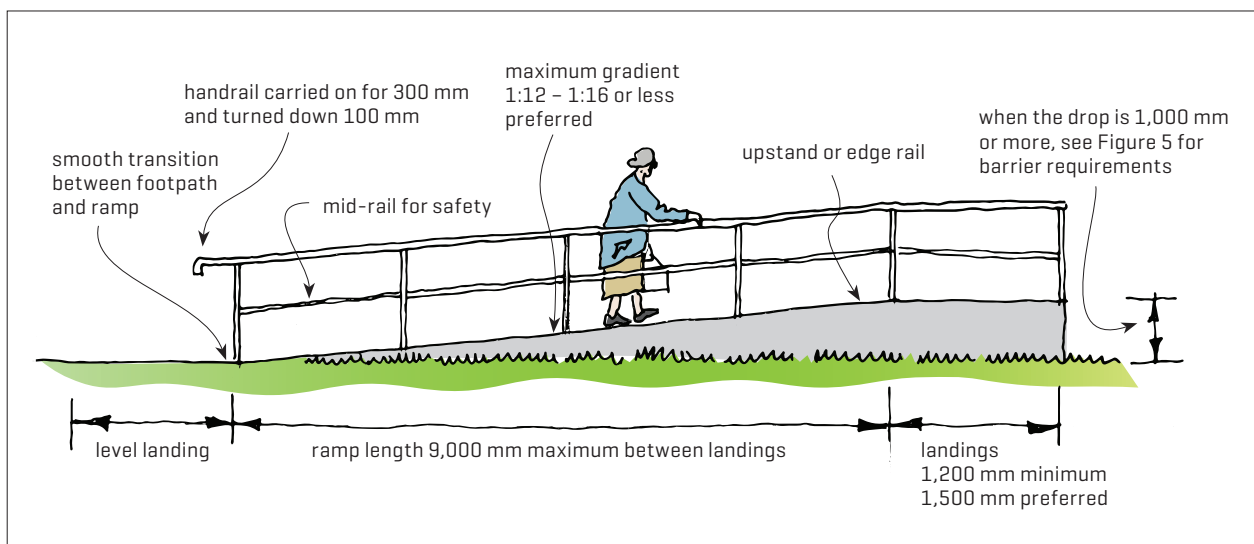

Figure 4. Double handrail for ramp with drop of less than 1,000 mm.

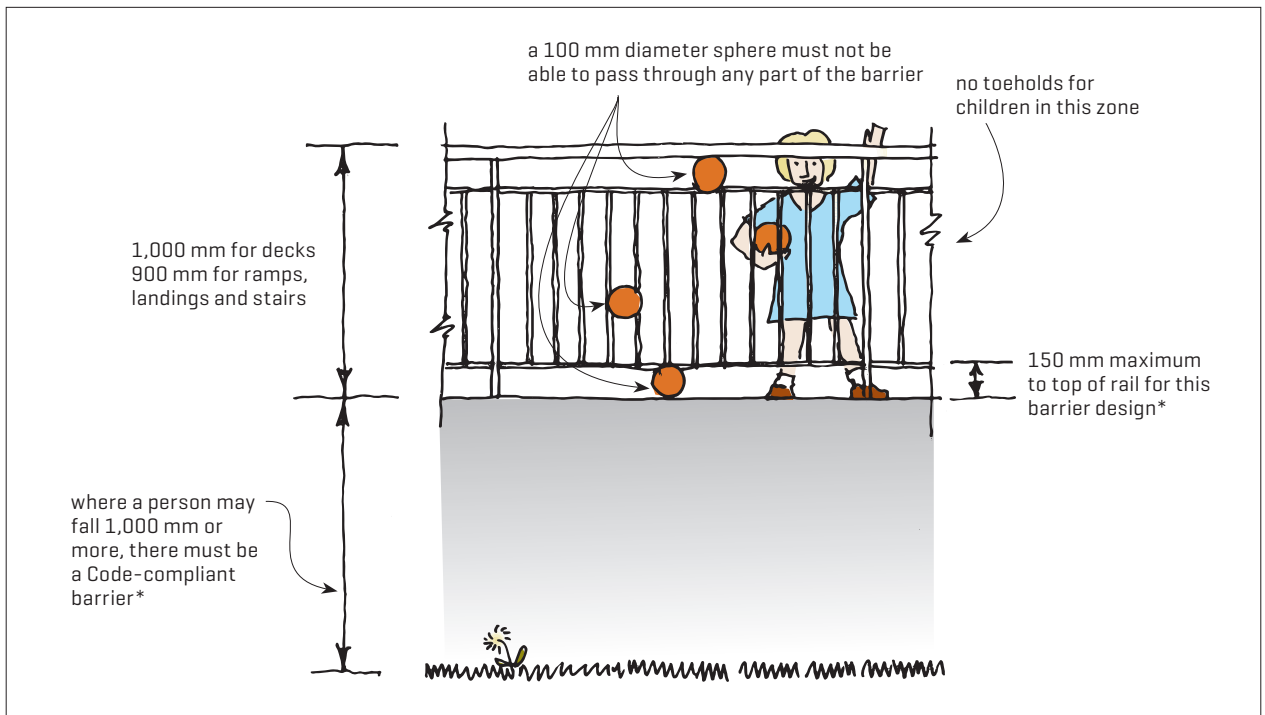

Figure 5. Barriers for routes where the drop is 1,000 mm or more.

\*The barrier design can be other configurations. See Acceptable Solution F4/AS1 Figures 1 and 2 for more options. Note the height of the handrails is a separate requirement. These must be 840–900 mm above the surface.

**4.0.2** If artificial lighting is provided, make sure switches are positioned at the top and bottom of the ramp and that they are easy to identify. If time-delay switches or movement or light sensors are used, make sure the settings will allow enough time for all users to pass before the lights are switched off automatically – people with reduced mobility can take longer.

## 5 AT THE ENTRANCE

**5.0.1** All users should be able to access the main entrance of a house and preferably also a secondary entrance that could also be used as an egress route.

**5.0.2** The ideal entrance will:

- be easily identified
- be level entry with no steps
- be sheltered
- be visible from inside the house via a window, glazed door panel or fish-eye lens
- have a seat and parcel shelf
- be well lit with a sensor-operated light
- have the minimum fall necessary to shed water
- have a sounding device (such as a buzzer) to announce visitors – this can include flashing internal lights if the occupant is deaf or has hearing loss
- have adequate manoeuvring space
- have an entrance door that is not too heavy to push open easily
- be at least 800 mm wide
- have lever door handles placed no higher than 1,000 m.

**5.0.3** However, the entrance doors of most dwellings are built with a step as a part of their design for weathertightness. Ranchsliders have protruding sill tracks to guide the sideways movement of the doors.

**5.0.4** Although some people can navigate a single step (with help if needed), steps and sill tracks at entrances can be a significant barrier to wheelchair users and an obstacle for people with prams and pushchairs, as complex manoeuvring is needed at the same time as dealing with the door.

**5.0.5** Many wheelchair users cope with level changes up to 20 mm. Any step larger than this can be impossible to navigate. A small change in level like this can be a trip hazard for some people with walkers or people who find raising their feet difficult. Visibility of any level change through colour contrasts is important.

**5.0.6** In new builds, level access without steps can be designed to be Code compliant using a decking landing or by installing slot or strip drains at the entrance.

**5.0.7** An existing entrance with a step could be made accessible with a decking landing and a horizontal gap to allow drainage (Figure 6a), and existing door sills can be replaced (Figure 6b). If a level change is slightly larger than 20 mm, a permanent threshold plate could be installed (Figure 6c), but only if the gradient will not be steeper than 1:8 over no more than 450 mm (NZS 4121:2001 section 7.1.4).

**5.0.8** It is important to note that there is no one-size-fits-all solution for creating compliant level access into a home. This must be designed and built to meet the exact circumstances of the construction. BRANZ also recommends checking with the local territorial authority to ensure that local building consent requirements are met.

## 6 ALTERNATIVES TO RAMPS

**6.0.1** Where the overall rise in an access route is too large and unavoidable, provide an alternative way to access the building. If a ramp up to an entrance would have to cover a long distance, it may be more cost-effective to build a short-rise lift instead.

**6.0.2** If the site allows it, consider building a new garage or carport level with the dwelling's entrance and installing a drive so that a vehicle does the climbing. Care must be taken not to block light to existing rooms.

**6.0.3** Instead of building a formal ramp, filling and landscaping can raise the ground level to provide access to an entrance.

**7.0.2** Ramps added to existing housing are usually made of either timber or concrete.

**7.0.3** Timber ramps are cheaper and faster to build than concrete ones (Figure 7). However, achieving an adequate level of slip resistance can be a problem, and grooved timber may not provide enough surface friction when wet. You may need to apply paint with a slip-resistant additive.

**7.0.4** Concrete ramps are more durable (Figure 8). Don't cast concrete against claddings such as fibre-cement and weatherboards. Maintain a clearance between the ground and perishable claddings.

**7.0.5** Avoid blocking existing subfloor ventilators and weepholes in brick veneer facings.

## 7 ADDING ACCESSIBLE ROUTES TO NEW AND EXISTING DWELLINGS

**7.0.1** For new builds, consider building on one level with vehicle access that is level with the dwelling entrance to remove the need for access ramps or steps.

## 8 MORE INFORMATION

BRANZ *Homes without barriers: A guide to accessible houses*

BRANZ Bulletin 663 *Universal design for access into homes by vehicle*

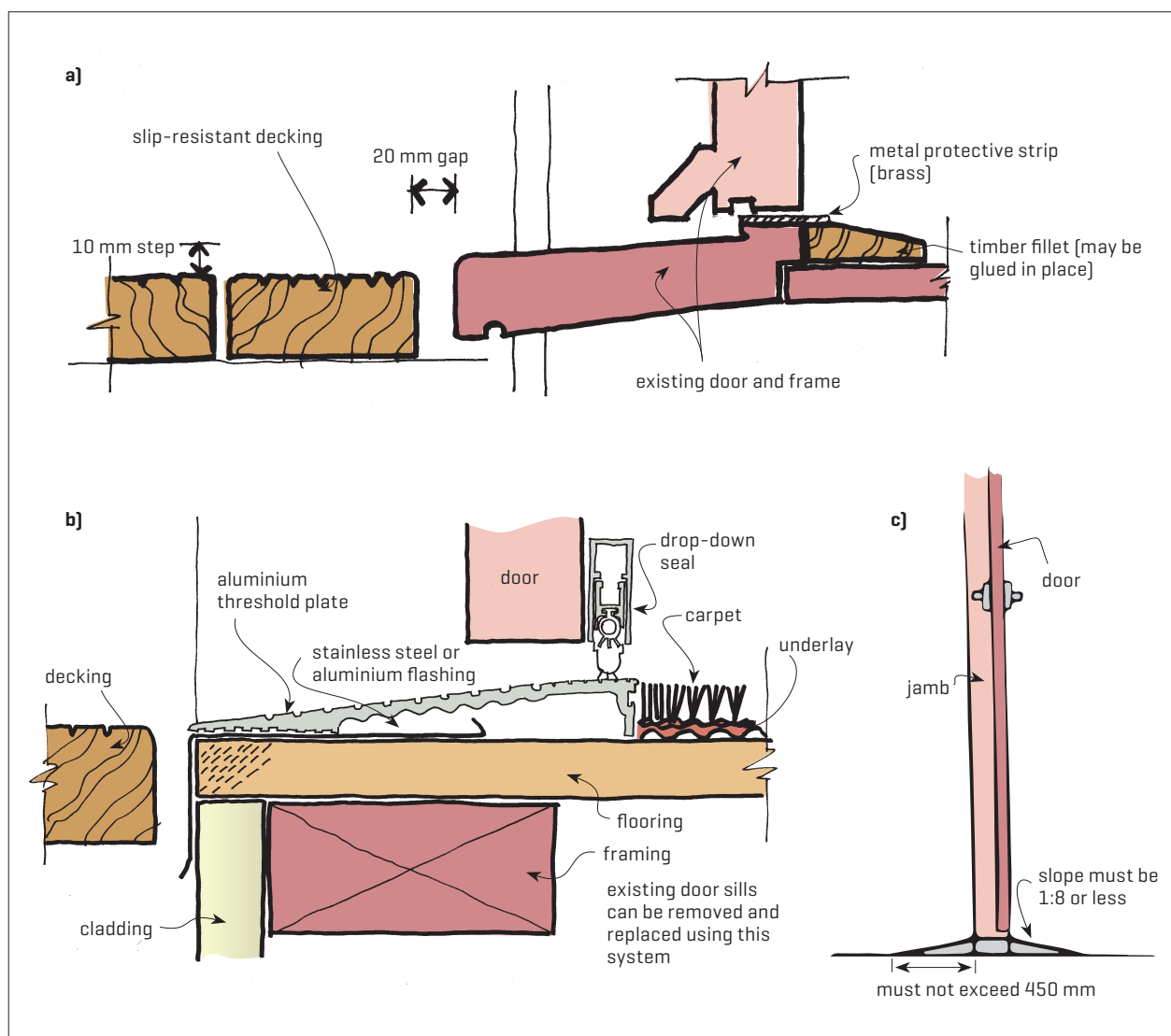

Figure 6. [a] Example detail providing level entry via a decking landing including a 20 mm gap for drainage. [b] Existing door sills can be removed and replaced. [c] Threshold ramps can assist where change in level is greater than 20 mm in some circumstances.



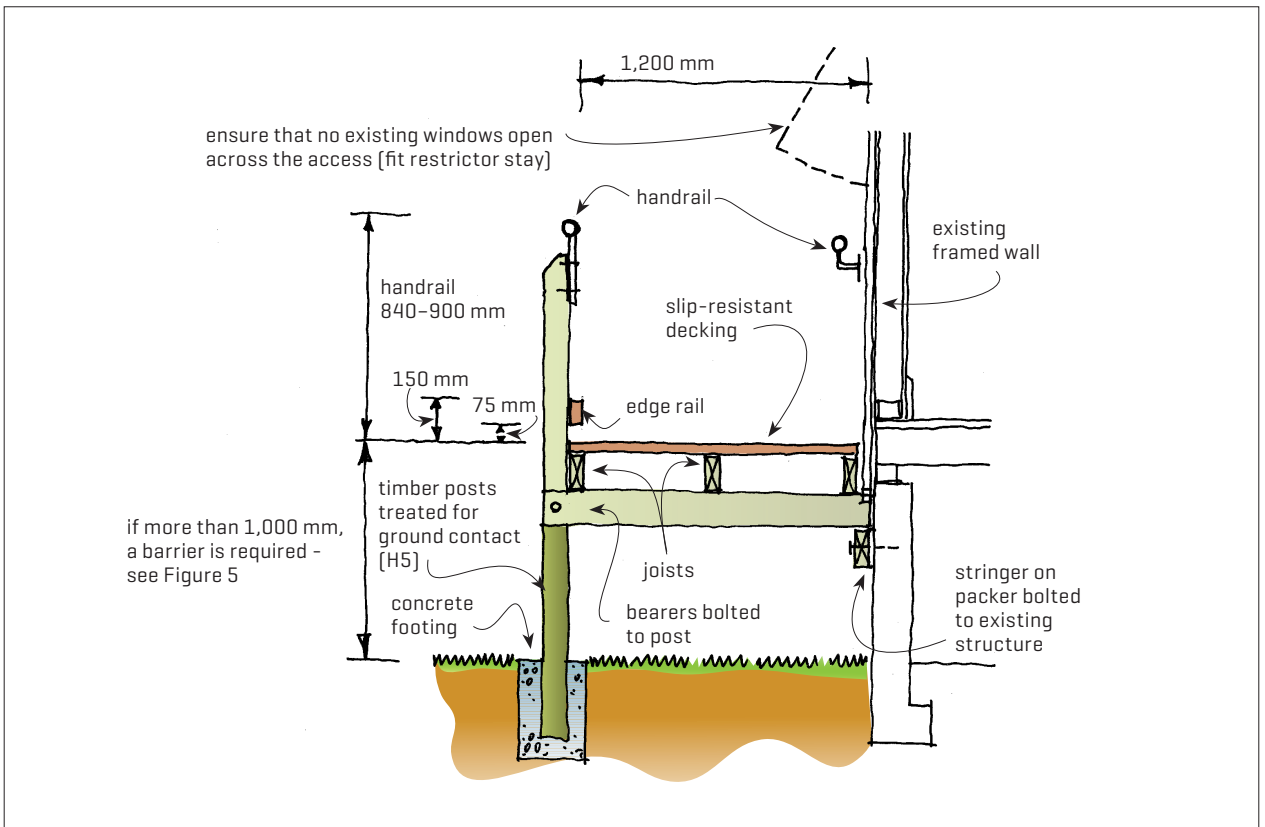

Figure 7. A timber ramp built against an existing house.

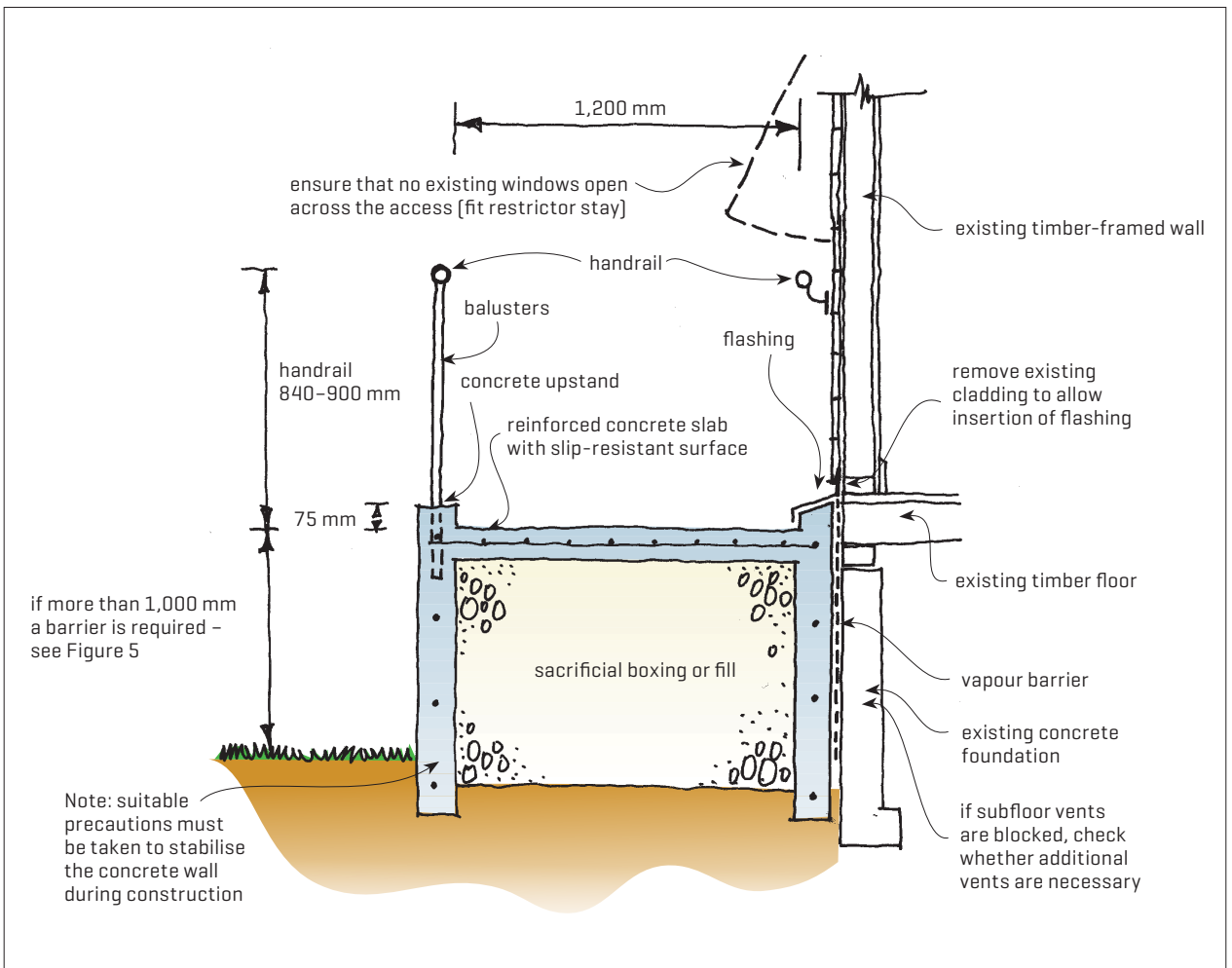

Figure 8. A concrete ramp built against an existing timber-framed house.



# CHALLENGING AOTEAROA NZ TO CREATE A BUILDING SYSTEM THAT DELIVERS BETTER OUTCOMES FOR ALL

## BRANZ ADVISORY HELP LINES

FOR THE BUILDING INDUSTRY

**0800 80 80 85**

FOR THE HOME OWNER AND PUBLIC ENQUIRIES

**0900 5 90 90**

Calls cost \$1.99 per minute plus GST. Children please ask your parents first.

 **BRANZ Find** [www.branzfind.co.nz](http://www.branzfind.co.nz)

HEAD OFFICE AND RESEARCH STATION

1222 Moonshine Road, Judgeford, Porirua, New Zealand

Private Bag 50 908, Porirua 5240, New Zealand

Telephone 04 237 1170 - Fax 04 237 1171

[www.branz.nz](http://www.branz.nz)

Standards referred to in this publication can be purchased from Standards New Zealand by phone 0800 782 632 or by visiting the website: [www.standards.co.nz](http://www.standards.co.nz).

Please note, BRANZ books or bulletins mentioned in this publication may be withdrawn at any time. For more information and an up-to-date list, visit BRANZ Shop online: [www.branz.nz](http://www.branz.nz) or phone BRANZ 0800 80 80 85, press 2.

Disclaimer: The information contained within this publication is of a general nature only. BRANZ does not accept any responsibility or liability for any direct, indirect, incidental, consequential, special, exemplary or punitive damage, or for any loss of profit, income or any intangible losses, or any claims, costs, expenses, or damage, whether in contract, tort (including negligence), equality or otherwise, arising directly or indirectly from or connected with your use of this publication, or your reliance on information contained in this publication.

ISSN 1178-4725 (Print) 2537-7310 (Online)

Copyright © BRANZ 2021. No part of this publication may be photocopied or otherwise reproduced without the prior permission in writing from BRANZ.