



SPECIFYING WINDOWS AND DOORS UNDER H1

October 2022

- The 5th edition of compliance documents for Building Code clause H1 *Energy efficiency* significantly increases minimum thermal performance requirements.
- Many window and glazing systems that complied with the 4th edition will no longer meet the new requirements.
- This bulletin guides architects and designers in understanding and specifying windows and doors that comply with H1/AS1 and H1/VM1 5th edition amendment 1.

1 INTRODUCTION

1.0.1 On 29 November 2021, the Ministry of Business, Innovation and Employment (MBIE) announced changes to the minimum thermal performance requirements for compliance with New Zealand Building Code clause H1 *Energy efficiency*. The 5th edition of Acceptable Solution H1/AS1 and Verification Method H1/VM1 incorporates higher minimum construction R-values for roofs, floors and windows and minor increases for some walls.

1.0.2 For windows, this change addresses where heat is lost or gained from glass and/or window frame surfaces after it passes through these materials. It does not address the next most important method (or mechanism) of heat flow in windows – the passage of solar radiation through the window. The solar heat gain coefficient (SHGC) effectively measures how well a window blocks heat from the sun. Excessive radiative heat flow can lead to houses overheating, which is a growing problem in Aotearoa New Zealand. MBIE has said this will be considered in a future revision of H1.

1.0.3 The three climate zones given in Appendix B in NZS 4218:2009 *Thermal insulation – Housing and small buildings* are replaced by six climate zones in Appendix C in the updated H1/AS1 and H1/VM1. [The six new climate zones also appear in H1/AS2 and H1/VM2 for larger buildings, which are outside the scope of this bulletin.]

1.0.4 The new minimum requirements represent a significant change. The minimum thermal performance for windows in the new zones 5 and 6 [part of the old zone 3] jumps from R0.26 to R0.50 [with R-value units measured in m²K/W]. Most window and glazing systems installed in the past do not achieve this new value and therefore cannot be used in new building work when using the schedule method to demonstrate compliance.

1.0.5 The H1/AS1 and H1/VM1 5th edition amendment 1 documents will replace the 4th edition from 3 November 2022. From this date, the 4th edition H1 documents can no longer be used for building consent applications.

1.0.6 The 5th edition documents include new methodologies for establishing the thermal resistance of several building elements including windows, doors and skylights. From 3 November 2022, only these new methodologies can be used.

1.0.7 There is a two-step transition for all windows and doors in climate zones 1 and 2 [the upper North Island]:

- From 3 November 2022, the minimum R-value is R0.37.
- From 2 November 2023, the minimum rises to R0.46.

1.0.8 For housing only, in zones 3-6 there is also a two-step process:

- From 3 November 2022, the minimum R-value is R0.37 for climate zones 3-6.
- From 1 May 2023, the minimum rises to R0.46 for climate zones 3 and 4.
- From 1 May 2023, the minimum rises to R0.50 for climate zones 5 and 6.

1.0.9 For buildings up to 300 m² that are not housing, the minimum R-values from 3 November 2022 are R0.46 in zones 3 and 4 and R0.50 in zones 5 and 6.

1.0.10 The scope of H1/AS1 and H1/VM1 5th edition has also changed, now only applying to all housing, and buildings up to 300 m².

1.0.11 For more details about compliance with clause H1, see MBIE’s Building Performance website www.building.govt.nz.

1.0.12 This bulletin focuses on Building Code compliance. There are other areas of window design and specification that have a substantial impact on the overall thermal performance of a house:

- Window size and location – northern walls should have more and larger windows to allow passive solar heating of living spaces. Southern walls should have fewer and smaller windows to reduce heat losses. Western walls should have windows designed to limit overheating from late afternoon and evening sun.
- Opening area of windows and how far they open – to allow ventilation for cooling in summer.
- Shade devices – overheating is a growing problem in New Zealand houses. While window size and location play a role in managing this, glazing systems that manage solar heat gain and external shade devices such as eaves [on north-facing windows] and roller blinds [on west-facing windows] should also be considered.
- Window installation – this is addressed in section 6.

1.0.13 Factors in window selection not connected to thermal performance, such as the requirements of NZS 4223.3:2016 *Glazing in buildings – Part 3: Human impact safety requirements*, are outside the scope of this bulletin.

2 WINDOW AND DOOR REQUIREMENTS UNDER H1/AS1 AND H1/VM1 5TH EDITION

2.0.1 The new minimum construction R-value requirements are given in the H1/AS1 and H1/VM1 5th edition documents [Table 1]. The construction R-value is the total thermal resistance of all the various physical elements that make up a window system.

Table 1. Minimum construction R-values required for vertical windows and doors in new building work under the schedule method for housing, and buildings up to 300 m².

Climate zone	3 November 2022	1 May 2023	2 November 2023
1 and 2	0.37	0.37	0.46
3 and 4	0.37 [housing] 0.46 [not housing]	0.46	0.46
5 and 6	0.37 [housing] 0.50 [not housing]	0.50	0.50

2.0.2 The requirements for working out the construction R-value of windows, doors and skylights have been revised and are given in Appendix E in H1/AS1 and H1/VM1. [The thermal performance tables for windows in NZS 4218:2009 no longer apply.] Table E.1.1.1 in Appendix E in H1/AS1 is to be used for housing only. For other building types, use the calculation method in H1/VM1. The construction options for insulating glazing units (IGUs – double or triple glazing) in Table E.1.1.1 are:

- framing material – aluminium, thermally broken aluminium, uPVC and timber
- glazing – double or triple pane (single glazing is not an option)
- spacer type – aluminium or thermally improved
- gas filling – dry air, argon or krypton
- glass – low-E (low-emissivity – with four performance levels) or clear glazing
- U-values [in W/m^2K] – for the thermal transmittance of the centre of the glazing unit only [U-values are the inverse of R-values]
- R-values [in m^2K/W] – for the thermal resistivity of complete windows, accounting for both the glazing and the frames.

3 HOW WINDOW ELEMENTS IMPACT ON THERMAL PERFORMANCE

3.0.1 Understanding the role and performance of each of these elements, from framing to the type of glass used, is key to understanding a window's overall thermal performance.

3.1 FRAMING MATERIAL

3.1.1 Timber and uPVC window frames offer the best thermal performance because they are relatively poor conductors of heat, followed by thermally broken aluminium frames. Aluminium itself gives a relatively poor thermal performance because of its high thermal conductivity.

3.2 THERMALLY BROKEN ALUMINIUM

3.2.1 To prevent rapid heat loss or gain through a solid aluminium frame between the interior and the exterior, a thermal break is designed into the frame. The inner and outer parts of the frame are held together by a connection with very low thermal conductivity – typically an extremely tough and durable type of reinforced plastic called polyamide [Figure 1]. BRANZ testing has confirmed that aluminium frames with this feature can significantly reduce heat transfer through the frame.

3.2.2 The thermal performance of thermally broken aluminium frames, in contrast to uPVC or timber frames, relies on installation that ensures the internal aluminium half-shell is not exposed to outside air. The thermal breaks of thermally broken aluminium frames cannot fulfil their function if outside air can reach the internal half-shell.

3.3 SPACERS

3.3.1 Spacers separate the glass panes in a double or triple-glazed window. They can be made of aluminium or, preferably, from a material with much lower thermal conductivity that reduces heat loss, commonly described as a warm edge space or thermally improved spacer [Figure 2].

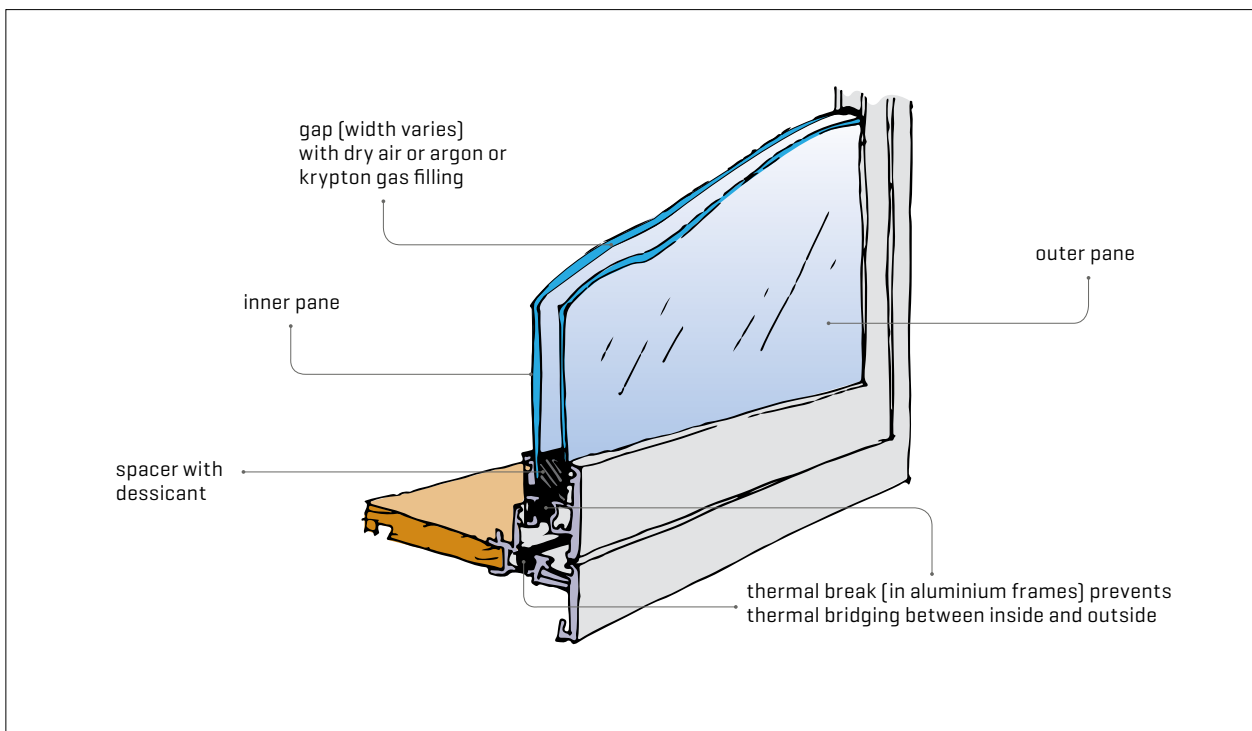

Figure 1. Typical thermally broken aluminium frame.

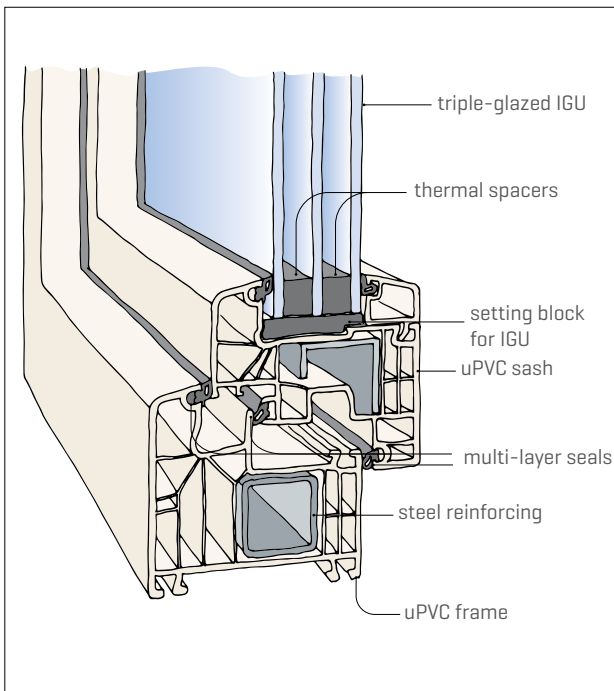

Figure 2. Thermal spacers in a triple-glazed uPVC window.

3.4 LOW-E

3.4.1 Low-E (low-emissivity) glass has a microscopically thin transparent metal coating that allows light through in both directions but reflects long-wave infrared radiation and associated heat back, allowing glazing to keep a house warmer in winter or cooler in summer. The impact of low-E glazing in both summer and winter needs to be considered – a slight compromise at one time of year may be necessary to achieve an overall better energy performance outcome.

3.4.2 While low-E glazing is sometimes discussed as a single product, there is a wide range of low-E coatings available with different attributes and levels of performance. Table E.1.1.1 in Appendix E in H1/AS1 refers to Low E₁, Low E₂, Low E₃ and Low E₄ [developed for the purpose of the table]. The numbers indicate different thermal performance levels of low-E coatings from basic to very high.

3.4.3 The technology of low-E glass has improved considerably in recent years, with newer products in some cases giving 10 times the thermal performance of older low-E glazing. Double glazing with the newest low-E coatings can perform about as well as some entry-level triple glazing but without the additional weight and size of triple-glazed windows.

3.5 IGU GAS FILL

3.5.1 The options for gas fill in IGUs in H1/AS1 and H1/VM1 are air, argon and krypton.

3.5.2 Argon is a common gas [it forms about 1% of Earth's atmosphere] and is a better insulator than air, reducing window heat loss by 3–9% compared with an air-filled IGU. Krypton is an even better insulator than argon but is only 1 part per million of the atmosphere

so is more expensive. IGUs with krypton filling have not been commercially produced in Aotearoa New Zealand to date (2022) although that may change. Overseas, krypton is often used in reglazing heritage windows where there is a narrower gap between panes.

3.6 OTHER CONSIDERATIONS AROUND THERMAL PERFORMANCE

3.6.1 There are other aspects of windows and doors that can have an impact on thermal performance but are not specifically addressed in the updated clause H1:

- Distance between glass panes – a wider gap between the glass [12 or 16 mm rather than 8 mm] will usually give an increase in R-value for air, but gas fills work better with smaller gaps. The improvement can be significant with high-performance low-E glazing.
- Multiple layers of air seals – a double seal in the frame [Figure 2] can reduce the movement of air inside framing and provide better thermal performance than a single seal.

4 WEERS

4.0.1 BRANZ and the Window and Glass Association New Zealand developed a scheme called the Window Energy Efficiency Rating System (WEERS). It combines the thermal performance of the frame and glazing together with window size to calculate the specific thermal performance for any window. Window suppliers can use this to calculate the thermal performance of windows for housing [Figure 3]. Some window suppliers provide a WEERS certificate that records the R-value of each window and the R-value for the house/lot. WEERS implements the international standard ISO 10077-2:2018 *Thermal performance of windows, doors and shutters – Calculation of thermal transmittance – Part 2: Numerical method for frames*. The calculation used by WEERS is consistent with the H1/VM1 window construction calculation methodology.



Figure 3. A WEERS label shows the thermal performance of windows.

Table 2. Construction R-values [m²K/W] for vertical windows.

Construction R-values for generic vertical window systems in H1/AS1 5th edition and solar heat gain coefficient (SHGC)									
The glazing unit R-values are based on IGUs available from large New Zealand suppliers (some may not be readily available currently)					Generic frame types and average frame %				
					Aluminium	Thermally broken	uPVC	Timber – 56 mm	
					23%	27%	34%	41%	
Generic IGU description		Gas fill (90% pure)	Spacer	SHGC	R _{window} [m ² K/W]				
Double glazing	4 Clear / 16 / 4 Clear		Air	Aluminium	0.77	0.26	0.32	0.40	0.44
	Low-E ₁ / Clear		Argon	Aluminium	0.56	0.30	0.39	0.50	0.56
	Low-E ₂ / Clear		Argon	Improved	0.55	0.33	0.42	0.56	0.63
	Low-E ₃ / Clear		Argon	Improved	0.57	0.35	0.46	0.63	0.71
	Low-E ₄ / Clear		Argon	Improved	0.54	0.37	0.50	0.69	0.77
	Low-E ₄ / Clear		Krypton	Improved	0.37	0.40	0.54	0.76	0.85
Triple glazing	Clear / Clear / Clear		Air	Improved	0.69	Not available	0.38	0.50	0.56
	Low-E ₂ / Clear / Clear		Argon	Improved	0.50	Not available	0.48	0.66	0.74
	Low-E ₃ / Clear / Clear		Argon	Improved	0.52	Not available	0.52	0.73	0.81
	Low-E ₃ / Low-E ₃ / Clear		Argon	Improved	0.47	Not available	0.59	0.86	0.95
	Low-E ₄ / Low-E ₄ / Clear		Argon	Improved	0.43	Not available	0.62	0.91	1.01

Notes:

1. The window schedule is from a 2021 aluminium window specification from a large group builder using window frames from a large window supplier.
2. WEERS modelling methods were applied, with modifications.
3. There is considerable variation in uPVC products in New Zealand so the uPVC results may not be as representative as the aluminium frames. Some uPVC providers may struggle to meet these figures, while others will easily exceed them.

5 SPECIFYING WINDOWS

5.0.1 The first considerations for door and window specification are likely to be approximate size, type and purpose [fixed window, opening window, single door, bifold door and so on].

5.0.2 After this, the next determination to be made is thermal performance, R_{window}. This should come before considering other requirements such as visible light transmission, UV elimination, SHGC, security, privacy, noise control and ease of cleaning.

5.0.3 Most window and glazing systems that previously complied with H1 will not comply with the 5th edition. For example, a basic double-glazed aluminium-framed IGU [with clear glass, aluminium spacers and air fill] with its accepted R-value around R0.26, very commonly installed in new houses in recent years, will no longer comply for new building work anywhere in the country under the schedule method.

5.0.4 To check for compliance, the construction R-values for vertical windows and glazing in doors [R_{window}] in

housing can be determined using Table E.1.1.1 in Appendix E in H1/AS1.

5.0.5 Table E.1.1.1 in H1/AS1 – the same data is in Table 2 in this bulletin, with SHGC figures added – gives overall area-weighted average R-values from two houselots of windows for each of four different frame types [aluminium, thermally broken aluminium, uPVC and timber] and a range of glazing options. The numbers were calculated by BRANZ.

5.0.6 As noted above, there was no change to the SHGC requirements in the 5th edition update of H1. Until this is addressed in a future update, architects and designers should pay particular attention to ensuring that the windows they specify do not contribute to a house overheating in summer.

6 INSTALLATION ISSUES

6.0.1 How windows are installed in a building can have a significant impact on their thermal performance. Many new windows have been installed surface mounted with the cladding. However, to ensure continuity of

the thermal envelope and to maximise the benefits of thermally efficient framing, the window should ideally be installed in line with the centre of the insulating layer, either rebated as with brick cladding or recessed into the wall.

6.0.2 MBIE, industry bodies and BRANZ are all well aware of the need for more practical guidance and details for window installation that does not compromise a building’s thermal envelope while still maintaining weathertightness. Be wary of making changes to window positioning without fully understanding the weathertightness implications. BRANZ, MBIE and industry bodies are working and testing improved installation details for weathertightness. Guidance will be published once satisfactory results have been achieved.

7 SKYLIGHTS

7.0.1 The new minimum requirements for skylights are shown in Table 3. As with vertical windows, there has been a significant increase from the earlier minimum requirement. For example, in new climate zones 5 and 6, the minimum has increased from R0.31 to R0.62.

7.0.2 Guidance for calculating the construction R-value of skylights is given in Appendix E in H1/AS1 and H1/VM1. There is no table showing construction R-values of generic skylights. H1/AS1 and H1/VM1 require skylight R-value calculations to consider the effects of horizontal or angled glazing on the heat transfer. The performance reduction for inclined IGUs means that the values in Table E.1.1.1 in H1/AS1 are not representative of performance values for skylight frame and glazing combinations. Designers and specifiers should therefore check that R-values claimed by suppliers have been determined in accordance with H1/AS1 or H1/VM1 and that they do not represent vertical installation.

7.0.3 The limitation on skylights when using the schedule method of determining compliance has not changed – the skylight area must be no more than 1.5 m² or 1.5% of the total roof area [whichever is greater].

7.0.4 There has been a minor change to the definition of a skylight in the new H1/AS1. It retains the earlier wording “translucent or transparent parts of the roof” but now also specifically includes both frames and glazing.

7.0.5 Skylights are typically used for increasing daylighting in a house. They should be used sparingly because of their two major drawbacks:

- Over a year, they almost always lose more energy than they gain.
- In summer months, they will contribute to overheating. [H1/AS1 now includes a comment that excessive skylight areas should be avoided to prevent overheating from excessive solar heat gains.]

8 MORE INFORMATION

BRANZ

Bulletin 658 *Timber windows*

MBIE

Building Performance – www.building.govt.nz

Window and Glass Association New Zealand

Resource directory – www.wganz.org.nz/resource-directory

Table 3. Minimum construction R-values required for skylights in new building work under the schedule method.

Climate zone	3 November 2022	1 May 2023
1-2	0.37 [housing] 0.46 [not housing]	0.46
3-4	0.37 [housing] 0.54 [not housing]	0.54
5-6	0.37 [housing] 0.62 [not housing]	0.62



CHALLENGING AOTEAROA NZ TO CREATE A BUILDING SYSTEM THAT DELIVERS BETTER OUTCOMES FOR ALL

BRANZ ADVISORY HELP LINES

FOR THE BUILDING INDUSTRY

0800 80 80 85

FOR THE HOME OWNER AND PUBLIC ENQUIRIES

0900 5 90 90

Calls cost \$1.99 per minute plus GST. Children please ask your parents first.

 **BRANZ Find** www.branzfind.co.nz

HEAD OFFICE AND RESEARCH STATION

1222 Moonshine Road, Judgeford, Porirua, New Zealand

Private Bag 50 908, Porirua 5240, New Zealand

Telephone 04 237 1170 - Fax 04 237 1171

www.branz.nz

Standards referred to in this publication can be purchased from Standards New Zealand by phone 0800 782 632 or by visiting the website: www.standards.govt.nz.

Please note, BRANZ books or bulletins mentioned in this publication may be withdrawn at any time. For more information and an up-to-date list, visit BRANZ Shop online: www.branz.nz or phone BRANZ 0800 80 80 85, press 2.

Disclaimer: The information contained within this publication is of a general nature only. BRANZ does not accept any responsibility or liability for any direct, indirect, incidental, consequential, special, exemplary or punitive damage, or for any loss of profit, income or any intangible losses, or any claims, costs, expenses, or damage, whether in contract, tort (including negligence), equality or otherwise, arising directly or indirectly from or connected with your use of this publication, or your reliance on information contained in this publication.

ISSN 2537-7310 [Online]

Copyright © BRANZ 2022. No part of this publication may be photocopied or otherwise reproduced without the prior permission in writing from BRANZ.

This bulletin was reviewed and republished in October 2022. Minor updates were made to the original publication of the same name and issue number published in April 2022.