



**Guide to
Passive Fire Protection
in Buildings**

Original manuscript	Ed Soja
Technical editor	Colleen Wade
Design and layout	Koast Graphics Ltd
ISBN	978-1-927258-75-0 (PDF) 978-1-927258-76-7 (epub)
First released	March 2017
Copyright	BRANZ Ltd, 2017
Address	BRANZ Ltd 1222 Moonshine Road, Judgeford 5381 Private Bag 50908, Porirua 5240 New Zealand
Phone	+64 4 237 1170
Fax	+64 4 237 1171
BRANZ Shop	www.branz.nz



ALL RIGHTS RESERVED. The information contained herein is entitled to the full protection given by the Copyright Act 1994 to the holders of this copyright. Details may only be downloaded, stored or copied for personal use, by either an individual or corporate entity, for the purposes of the carrying out of a construction-related or other business or for private or educational use. Copying for the purposes of inclusion in trade or other literature for sale or transfer to a third party is strictly forbidden. All applications for reproduction in any form should be made to the Channel Delivery Team Leader, BRANZ Ltd, Private Bag 50908, Porirua City, New Zealand.

Disclaimer: The information contained within this publication is of a general nature only. BRANZ does not accept any responsibility or liability for any direct, indirect, incidental, consequential, special, exemplary or punitive damage, or for any loss of profit, income or any intangible losses, or any claims, costs, expenses, or damage, whether in contract, tort (including negligence), equity or otherwise, arising directly or indirectly from or connected with your use of this publication, or your reliance on information contained in this publication.

Any standard referred to within this publication can be purchased from Standards New Zealand by phoning 0800 782 632 or by visiting www.standards.co.nz. Please note, the BRANZ books and bulletins mentioned in this publication may be withdrawn at any time. For more information and an up-to-date list, visit BRANZ Shop online: www.branz.nz or phone BRANZ 0800 80 80 85, press 2.

ACKNOWLEDGEMENTS

BRANZ would like to thank the following people and organisations for their time and expertise in compiling and reviewing this guide:

Aaron Nicholson (Beca)

Ed Claridge (Auckland Council)

Evan Geeves (Kalmar Construction)

Fire Protection Association of New Zealand, Passive Special Interest Group

Hans Gerlich (Winstone Wallboards)

Jeremy Chang (Holmes Fire/Christchurch City Council)

Kevin Frank (BRANZ Ltd)

Michael Belsham (Ministry of Business, Innovation and Employment)

Peter Reddin and Debbie Scott (OnFire Consulting)

CONTENTS

////	1. Introduction	1
////	2. Definitions and abbreviations	3
////	3. What is passive fire protection?	6
	Separation of firecells	8
////	4. New Zealand Building Code and performance requirements	9
	Determining the fire resistance of elements of building construction	10
	Classification of fire resistance	12
	Achieving approval of a fire-resisting construction	13
	Changes to existing buildings	16
////	5. Participants and roles	17
	Designer/architect/engineer	19
	Building consent officer/building inspector	20
	Project manager/head contractor/installer	20
	Independent qualified person	21
	Third-party inspector	22
	General requirements of participants	22
	Training	23
////	6. On-site installation	24
	Consented documents	24
	Specialist installation contractors	25
	Substitution or hybridisation	25
	On-site supervision	26
	Documenting the installation	26
	Labelling	28
	Code Compliance Certificate	28
	Verification of performance	29
	Retrofit or renovations	29
////	7. Specific installation requirements	30
	Fire protection coatings	30
	Sealing penetrations	31
	Passive fire protection systems – index	33
	Walls – timber-framed (single or multi-layers)	34
	Walls – masonry	35

Walls – composite	36
Cavity barriers	37
Doors – doorsets	40
Doors – lifts	44
Shutters	46
Ducts	47
Fire dampers	48
Structural fire protection	51
Intumescent coatings	52
Penetration seals – electrical and information technology	53
Penetration seals – plumbing	61
Penetration seals – linear gaps	64
 8. Checklists	65
Checklist 1: Fire and smoke barriers	65
Checklist 2: Fire-resistant doorsets	67
Checklist 3: Shutters	70
Checklist 4: Ducts	72
Checklist 5: Fire dampers	73
Checklist 6: Penetration seals	75

FIGURES

Figure 1. Passive fire protection building components	7
Figure 2. Fire spread control using passive fire protection	7
Figure 3. Firecell separation	8
Figure 4. Typical project process for passive fire protection, showing two paths for specification and approval	18
Figure 5. Example of plan of penetration seals	27
Figure 6. Typical framed wall features	34
Figure 7. Typical block wall features	35
Figure 8. Typical composite wall features (for example, foamed plastics, cement, mineral wool sandwich panels)	36
Figure 9. Vertical cavity barrier in ceiling space	37
Figure 10. Cavity barrier – floor edge to curtain wall	38
Figure 11. Cavity barrier in taller wall	39
Figure 12. Typical doorset features – timber-framed wall and steel door frame	40
Figure 13. Typical doorset features – timber-framed wall and timber door frame	41
Figure 14. Typical doorset features – masonry wall	42
Figure 15. Typical doorset features – glazed	43
Figure 16. Typical lift doors – lobby	44
Figure 17. Typical lift doors – inside lift shaft	45
Figure 18. Typical vertical roller shutter features	46
Figure 19. Typical duct features	47
Figure 20. Typical fire damper features – metal	48
Figure 21. Typical fire damper features – metal in framed wall	49
Figure 22. Typical fire damper features – intumescent	50
Figure 23. Structural fire protection – fire-rated boards protecting steel columns	51
Figure 24. Intumescent coatings	52
Figure 25. Penetration seals – single cable	53
Figure 26. Penetration seals – single cable – bundles	54
Figure 27. Penetrations with fire-rated infill	55
Figure 28. Penetration seals – cables	56
Figure 29. Box penetration cable transits	57
Figure 30. Pillows	58
Figure 31. Penetration seals – power outlets	59
Figure 32. Recessed downlight cover	60
Figure 33. Penetration seals – plastic pipes – walls	61
Figure 34. Penetration seals – metal pipes – walls	62
Figure 35. Penetration seals – pipes – floors	63
Figure 36. Penetration seals – linear gap seals – floor or wall	64

TABLES

Table 1.	Examples of FRR specifications	12
Table 2.	Summary of roles	22
Table 3.	Example of a passive fire protection schedule	28

KEY TO DRAWINGS

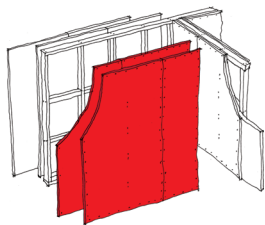

fire-rated plasterboard (applies to multi-layer and single layer walls; note that each manufacturer may colour their product differently)



metal (includes steel and copper)

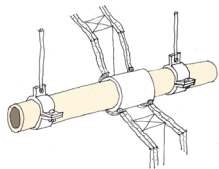

PVC

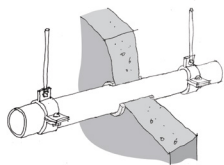

concrete

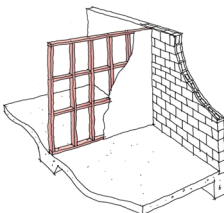

timber framing

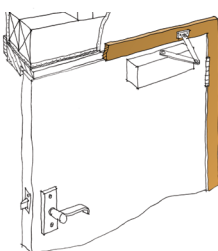

timber

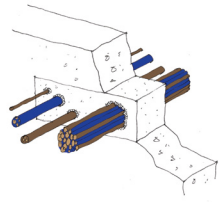

electrical cables

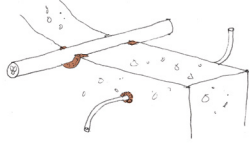

fire-rated sealant
(note that each manufacturer may colour their product differently)

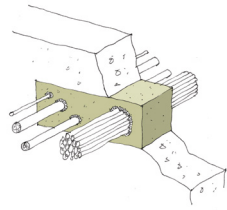

fire-rated mineral wool, slab board and blankets
(note that each manufacturer may colour their product differently)

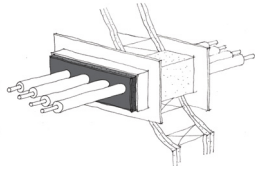

fire-rated PU foam sheet
(note that each manufacturer may colour their product differently)

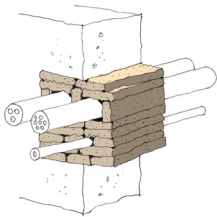

fire-rated pillows
(note that each manufacturer may colour their product differently)

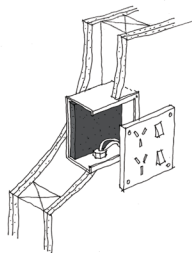

intumescent material
(note that each manufacturer may colour their product differently)

Notes

- Colours in the drawings are not representative of actual colours.
- Insulation has been omitted for clarity.



INTRODUCTION

Considerable evidence exists to show that, in a large proportion of buildings, passive fire protection is not being effectively designed, specified and delivered.¹ This potentially poses a serious life safety risk for building occupants and firefighters in the event of fire occurring, as well as increasing risk of fire spread and subsequent property damage. There is an overwhelming need for comprehensive guidance on how to design, specify, install, inspect, certify and maintain effective and resilient passive fire protection in New Zealand buildings.

The purpose of the guide is to enable the effective use of passive fire protection including providing the right product and installing it correctly in the right situation. It describes good practice for the specification, approval, installation and verification of passive fire protection. Specific processes may vary between jurisdictions and the professional people involved, but in all cases, the appropriate product must be correctly installed.

This guide introduces the principles of passive fire protection. It identifies the requirements of the New Zealand Building Code (NZBC), explains the terminology commonly used and identifies the main building components that have a passive fire protection role.

¹ FPANZ Research Report, *Determining Barriers to Industry Delivery of Fire-Safe Buildings in New Zealand*. FPANZ 2008.

This guide provides guidance on issues and good practice, including:

- specification
- installation
- verification/inspection
- record keeping.

The guide describes the process of verifying on-site installation and post-building consent procedures.

It is primarily intended for those involved in designing, specifying and installing passive fire protection but also provides sources of information for the certifier of passive fire protection and anyone involved with construction works in buildings.

The guide does not give information on how to determine the actual value of a fire resistance rating (FRR) for passive fire protection or how to assess the FRR of existing passive fire protection. This guide assumes that the required FRR to be achieved is known and gives information and advice on how to proceed.



DEFINITIONS AND ABBREVIATIONS

access panel	A removable component protecting an opening in a fire-resistant vertical or horizontal separating element used to access services and the like and may be either fixed or hinged. A horizontal access panel is often referred to as a hatch.
Alternative Solution	All or part of a building design that demonstrates compliance with the NZBC but differs completely or partially from the Acceptable Solutions or Verification Methods.
ANARP	As near as reasonably practicable.
annular	Ring shaped.
annular gap	A ring-shaped gap, such as between a pipe and the wall it penetrates.
AS (as in C/AS1–7)	Acceptable Solution of the NZBC clauses 1–6 <i>Protection from fire</i> .
BCA	Building consent authority, as defined in section 7 of the Building Act 2004. Most city and district councils are building consent authorities.
BOINZ	Building Officials Institute of New Zealand
Building Act 2004 (the Building Act)	The principal legislation dealing with building controls in New Zealand.
building consent	Consent to carry out building work granted by a BCA under section 49 of the Building Act 2004.
building element	Any structural or non-structural component or assembly incorporated into or associated with a building. Included are fixtures, services, drains, permanent mechanical installations for access, glazing, partitions, ceilings and temporary supports.
BWOF	Building warrant of fitness.
cavity barrier	A construction provided to close openings within a concealed space against the passage of fire or to restrict the spread of fire within such spaces.
CM	Construction monitoring. Refers to procedures for observing construction work.
collar – fire (or pipe)	Device used where a plastic pipe penetrates a fire-rated wall of floor/ceiling. Usually contains intumescent material within a steel tube that expands to seal the opening in a fire.

combustible	As deemed combustible when tested to AS 1530.1-1994 <i>Methods for fire tests on building materials, components and structures – Combustibility test for materials</i> .
competent authority (for the purposes of this document)	A person or entity that has relevant knowledge and experience of fire testing. It may include those involved in fire testing and assessment such as an IANZ signatory, a manufacturer's representative or other IANZ-accredited entities.
control joint	A joint between or within discrete elements of construction, which allows for relative movement of the elements.
C/VM2	Verification Method: Framework for Fire Safety Design for New Zealand Building Code clauses C1–C6 <i>Protection from fire</i> .
damper assembly	A movable closure in a duct or opening for the passage of air, which operates automatically to restrict the passage of fire or products of combustion past the damper.
damper – insulated	A damper that satisfies the integrity, leakage and insulation (temperature rise) requirements of AS 1530.4-2005 <i>Methods for fire tests on building materials, components and structures – Fire-resistance test of elements of construction</i> .
damper – intumescent fire	A closure that operates by intumescenting (swelling on application of heat) and is designed to prevent the passage of fire through a duct.
damper – mechanical fire	A mechanical closure operated automatically or manually and designed to prevent the passage of fire through a duct.
damper – smoke	A closure designed to prevent the passage of smoke through a duct.
damper – uninsulated	A damper that satisfies the integrity and leakage requirements of AS 1530.4-2005.
doorset	The complete assembly comprising a door leaf or leaves, including any glazed or solid panels adjacent to or over the leaves within the door frame, and hardware or other inbuilt features. Also includes a door frame, if any, with its fixings to the wall and, for a sliding or tilting door, all guides and their respective fixings to the lintel, wall or sill.
expanding PU foam	Polyurethane foam created when ejected from a cartridge. May be single component or two-pack. This is not an intumescent material.
firecell	Any space, including a group of contiguous spaces on the same or different levels within a building, which is enclosed by any combination of fire separations, external walls, roofs and floors.
fire damper	A device with a specified fire resistance rating complete with fixings and operating mechanism for automatically closing off an airway where it passes through a fire separation. See also <i>damper assembly</i> .
fire door	A doorset, single or multi-leaf, having a specified fire resistance rating and, in certain situations, a smoke control capability and forming part of a fire separation. The door, in the event of fire, if not already closed, will close automatically and be self-latching.
fire resistance rating (FRR)	The term used to describe the minimum fire resistance required of primary and secondary elements as determined in the standard test for fire resistance or in accordance with a specific calculation method verified by experimental data from standard fire resistance tests. It comprises three numbers giving the time in minutes for which each of the criteria (structural adequacy, integrity and insulation) are satisfied. It is always presented in that order, expressed as xx/yy/zz
fire-resistant air transfer grille assembly	A closure device (mechanical or intumescent) that is located within a separating element and has no reticulating ductwork on one or both sides of the penetration.
fire separation	Any building element that separates firecells or firecells and safe paths and provides a specified fire resistance rating.
fire shutter	A fire-rated device, complete with fixings and operating mechanism, for automatically closing off an opening in a fire separation or protected shaft.
fire stopping	A material or method of construction used to restrict the spread of fire within or through fire separations and having an FRR no less than that of the fire separation.

IANZ	International Accreditation New Zealand. Agency responsible for accrediting organisations and people to carry out tests and inspections in accordance with specific standards.
intumescent	A substance that swells as a result of heat exposure. Thin-film intumescent may be used as coatings to protect structural steel. High-expansion intumescent may be used in pipe collars.
IPENZ	Institution of Professional Engineers New Zealand Inc. IPENZ is New Zealand's professional body for engineers.
IQP	Independent qualified person. A person accepted by a local BCA or council as qualified to inspect, test, maintain and report on specified systems.
LBP	Licensed Building Practitioner
multiple penetration systems	Systems where large service openings are provided in a fire-separating element and are filled with infill material through which the services penetrate and are sealed individually or in groups to the infill material rather than to the parent element.
non-combustible	As deemed non-combustible when tested to AS 1530.1-1994.
NZBC	New Zealand Building Code – the regulations made under section 400 of the Building Act 2004.
PE rod	Polyethylene backing rod used to control the depth of sealant applied within a joint/gap.
PN22	IPENZ Practice Note 22: <i>Guidelines for Documenting Fire Safety designs</i> . https://www.ipenz.nz/home/news-and-publications/news-article/2015/09/07/practice-note-guidelines-for-documenting-fire-safety-designs-2011
penetration	An aperture through a fire-separating element for the passage of a service or services (as defined in AS 4072.1-2005 <i>Components for the protection of openings in fire-resistant separating elements – Service penetrations and control joints</i>).
penetration seal	The system used to maintain the fire resistance of a fire-separating element at the position where there is provision for services to pass through the element (as defined in AS 4072.1-2005).
penetration system	The assembly for test consisting of the penetrating service or services and the penetration seal, media or devices, together with any service-supporting construction (as defined in AS 4072.1-2005).
PS	Producer statement. A document from an engineer stating their professional opinion that parts of a building's design comply with the NZBC or that specific construction work has been completed in accordance with the building consent.
PU foam sheet	Polyurethane foam in the form of remanufactured sheets – similar to furniture foam.
service	A system or element used for the functioning of a building, for example, a cable, conduit, pipe, duct or flue.
smoke control door	A doorset that complies with Appendix C, C6.1.2 of C/AS1-7. A smoke control door will be self-closing, self-latching and fitted with smoke seals. It is required to have marking and labels complying with the relevant parts of NZS 4520:2010 Fire-resistant doorsets.
smoke separation	Under NZBC clause C <i>Protection from fire</i> Acceptable Solutions, "Any building element able to prevent the passage of smoke between two spaces. Smoke separations shall: a) Be a smoke barrier complying with BS EN 12101 Part 1, or b) Consist of rigid building elements capable of resisting without collapse: i) a pressure of 0.1 kPa applied from either side, and ii) self weight plus the intended vertically applied live loads, and c) Form an imperforate barrier to the spread of smoke, and d) Be of non-combustible construction, or achieve a FRR of 10/10/-, except that non-fire resisting glazing may be used if it is toughened or laminated safety glass."



3

WHAT IS PASSIVE FIRE PROTECTION?

Passive fire protection refers to the use of construction elements within a building that are designed to prevent or delay the spread of fire and/or smoke to different parts of the building. Passive fire protection is one of the methods used to protect buildings and people from fire. Other methods that may also be used include active fire protection such as fire sprinklers and alarms. This is supported by good fire safety management to ensure that fire protection is available at all times, facilitating escape in the event of fire and preventing damage to adjacent buildings.

Figure 1 illustrates the various forms of passive fire protection (adapted from AS 1851-2012 *Routine service of fire protection systems and equipment*). Each may also provide smoke separation as well as fire resistance.

The purpose of passive fire protection is to limit the effects of fire within a building by acting as a barrier to fire and smoke (Figure 2) or protecting structural components from fire that may cause early collapse. This is achieved by installing fire resistance rated elements of construction and controlling the flammability of construction materials. These materials are part of the building fabric and do not include building contents.

Two key aspects of passive fire protection are:

- resistance to fire - mainly concerned with the ability of a fire-separating element (such as a wall or floor/ceiling) to limit fire spread, including passage of fire products through the element, or to prevent collapse in the case of a loadbearing element (such as a column)
- reaction to fire - mainly concerned with the surface burning behaviour of an element or material (for example, Material Group Numbers) and the extent to which it promotes rapid flame spread or smoke production.

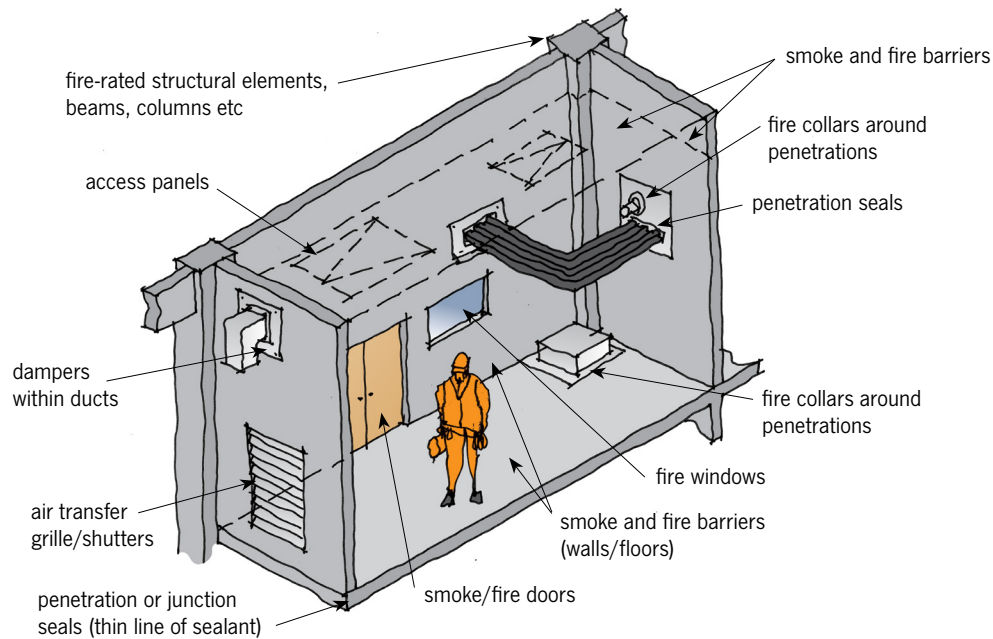

Figure 1. Passive fire protection building components

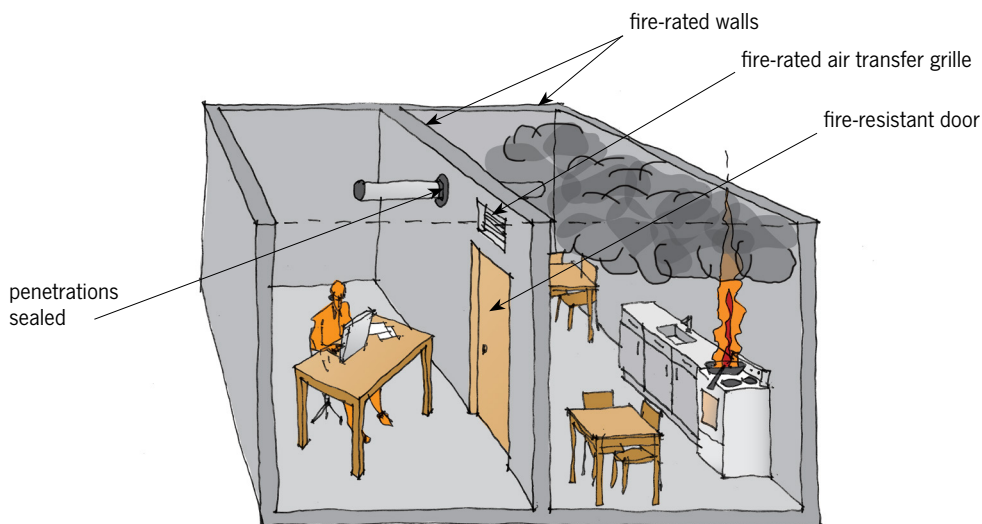

Figure 2. Fire spread control using passive fire protection

This guide deals exclusively with resistance to fire and smoke of construction elements in buildings.

The effects of fire include heat, flames, hot gases and smoke. Acceptable Solutions have prescriptive requirements for smoke separations, specifying the construction rather than a performance specification (such as maximum smoke leakage rate). This guide mainly applies to those aspects of C/AS1-7 relating to the passage of heat, flames and hot gases through fire separations. This guide can also be used to assist with the detailing of fire (and smoke) resistance of building elements for C/VM2 design and construction or in the case of Alternative Solutions.

Passive fire protection provides protection simply by being there. It has an established performance, verified by test data. It must be correctly specified, installed and maintained.

Passive fire protection is an important part of the fire safety features in a building and should ideally be subjected to the same rigorous installation documentation,

inspection and sign-off as active fire protection. For example, fire sprinkler systems complying with NZS 4541:2013 *Automatic fire sprinkler systems* are subject to an integrated set of rules covering their design, performance, installation and maintenance. These require regular tests, inspections and sign-offs using listed contractors and independently accredited certifiers.

Passive fire protection systems should be installed in strict accordance with the consented plans (if specifically identified in them) or the manufacturer's specifications. Any variations should be referred back to the designer or manufacturer and, if appropriate, submitted to the BCA for approval as an amendment to the consent.

Separation of firecells

Buildings may be subdivided into firecells designed to contain the fire and prevent its spread for a specified period of time. Firecells are separated using construction elements that are fire resistance rated for at least the specified period of time required for the firecell. Fire-resistant construction must be located to completely separate the intended firecell from the rest of the building. Where the fire separation meets unrated construction, such as a suspended ceiling, it should be continued and extend to reach another fire separation or the main boundaries of the building envelope (such as floors, external walls and ceiling/roof). All penetrations in fire separations, doors, dampers and services must be sealed to maintain the performance of the fire-rated construction. Figure 3 illustrates this concept of total separation.

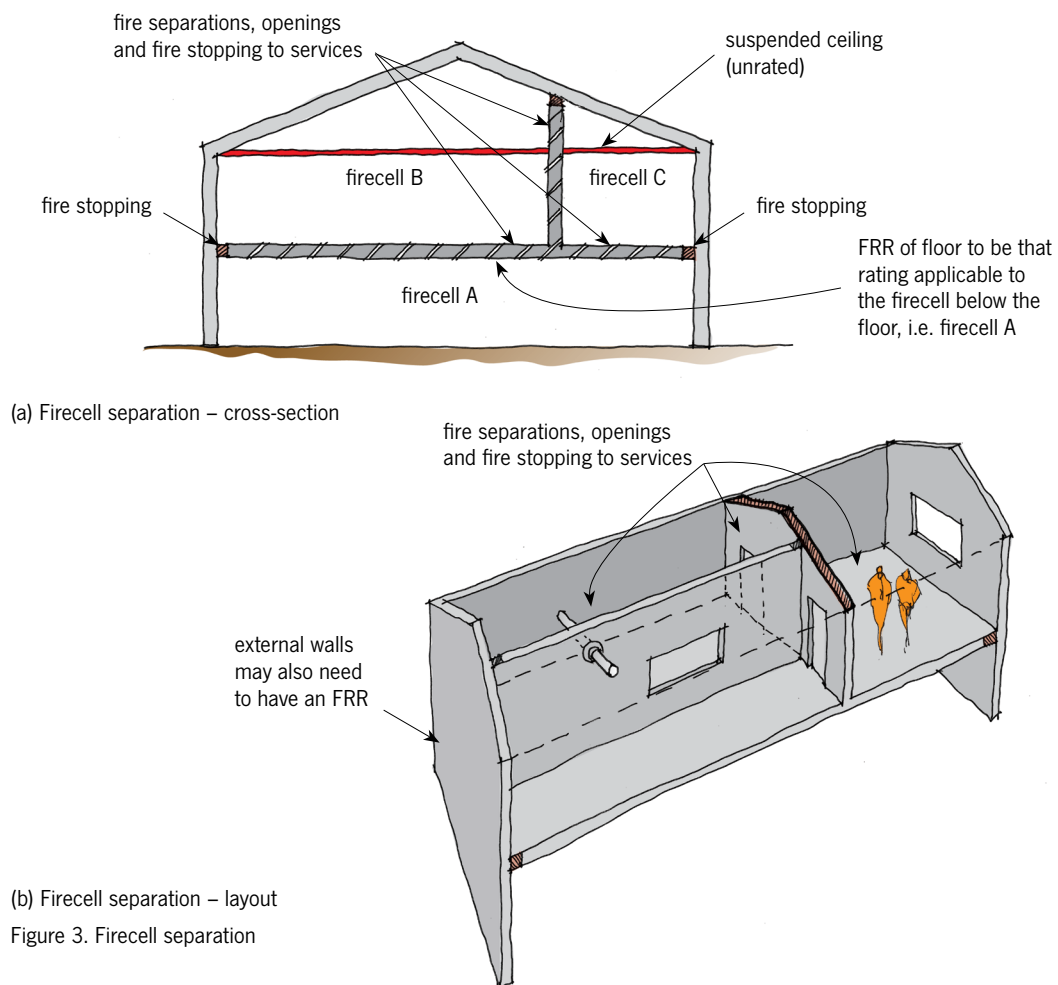



4

NEW ZEALAND BUILDING CODE AND PERFORMANCE REQUIREMENTS

The minimum requirements for fire protection in buildings are given by the NZBC. The NZBC is performance based, with a set of mandatory performance requirements.

Whether the building is a new build, existing building or a refurbishment, the requirements of the NZBC, via the Building Act, must be met. Meeting NZBC requirements may be achieved by:

- compliance with the Acceptable Solutions
- following a Verification Method
- an Alternative Solution
- an ‘as near as reasonably practicable’ (ANARP) solution for change of use or alterations in existing buildings.

Passive fire protection systems generally contribute to meeting clauses C1-C6 of the NZBC. For compliance with Acceptable Solutions C/AS1-7, Appendix C of the Acceptable Solutions gives the test methods and related standards by which the fire resistance rating (FRR) of passive fire protection is determined. These methods may also be used with C/VM2 and Alternative Solutions.

Passive fire protection systems are also required to satisfy NZBC clause B2 *Durability* to ensure that a building will continue to satisfy the performance requirements of the NZBC throughout its specified intended life. Passive systems must continue to perform for 5, 15 or 50 years depending on their function, difficulty of access and the ease of detecting their failure to comply. Further guidance on meeting NZBC clause B2 is outside the scope of this guide.

The following sections give the relevant test and installation standards in Acceptable Solutions C/AS1-7, Appendix C.

Establishing the required FRR for passive fire protection is not part of this guide.

Determining the fire resistance of elements of building construction

For compliance with the Acceptable Solutions for fire safety, these are the applicable standards (product tested to previous versions may no longer be applicable and require to be assessed for equivalence to the current standards):

- AS 1530.4-2005 *Methods for fire tests on building materials, components and structures - Fire-resistance test of elements of construction* and NZS/BS 476.20:1987 *Fire tests on building materials and structures - Method for determination of the fire resistance of elements of construction (general principles)*.
- NZS 4520:2010 *Fire-resistant doorsets*.
- AS 4072.1-2005 *Components for the protection of openings in fire-resistant separating elements - Service penetrations and control joints*.

(Note that, specifically for fire doors and service penetrations, the fire test standard specified in NZS 4520:2010 and AS 4072.1-2005 is AS 1530.4-2005.)

For compliance with C/AS1-7, no other standards should be used unless a competent authority has verified that the product has been tested using a standard that is equivalent to the specified standards in Appendix C of the Acceptable Solutions. A competent authority is one that has knowledge and experience of fire testing (see definition). In this case, the evaluation of equivalency would typically be included within an assessment report or letter of opinion.

The above standards may also be specified in C/VM2 or Alternative Solutions. In these cases, the fire designer might instead choose to specify a different standard. This would be an Alternative Solution, and the fire designer is responsible for ensuring the appropriateness of a different test standard and obtaining approval from the BCA. Discussion of this is beyond the scope of this guide, but further guidance is available at www.building.govt.nz/building-code-compliance/how-the-building-code-works/different-ways-to-comply/alternative-solutions/.

A product or Alternative Solution may also be subject to a technical assessment by a competent authority as to its performance in accordance with the standards referenced above.

For C/VM2 or an Alternative Solution, the use of any other standards will have to be justified to the BCA.



Pilot fire resistance furnace 2 m high × 1 m wide

The photo above gives a view of glazed door on a furnace, 2 m high × 1 m wide, used to conduct pilot-scale fire resistance tests. Full-scale fire resistance tests are conducted using furnaces up to 3 m wide × 4 m high. The furnace may also be horizontal to conduct tests on floors/ceiling or roof construction.

Classification of fire resistance

The fire resistance of a building element is fully described by the use of three numbers. Together, they give the fire resistance rating (FRR) expressed in the form structural adequacy/integrity/insulation. The numbers refer to the time in minutes for which each of the criteria are satisfied when the element is exposed to the temperature, pressure and applied load specified in the test procedure.

- **Structural adequacy** is the ability to support a vertical axial load and only applies to loadbearing elements of structure. A column or beam may have an FRR of 120/-/, or a loadbearing wall may have an FRR of 60/60/60.
- **Integrity** is the ability to prevent the passage of flame and hot gases measured by the creation of a gap or ignition of a cotton pad on the non-fire (unexposed) face.
- **Insulation** is the ability to limit the temperature rise on the non-fire (unexposed) face.

These terms are defined in the test standard AS 1530.4-2005. The unexposed face is sometimes referred to as the 'cold face'.

Structural adequacy applies to walls, floors and columns with a loadbearing function. Consideration of other structural aspects, such as identifying the potential load paths in a building exposed to fire or the ability of a fire-rated element to provide support to other elements, are not part of this guide.

Note that a '2-hour fire rating' is not a complete specification. It should be three numbers (in minutes), even if two of them do not apply - for example, 120/-/ for a column.

//// Table 1. Examples of FRR specifications

BUILDING ELEMENT	FRR	COMMENT
Loaded column	60/-/-	No integrity or insulation as it only provides a structural support function
Non-loadbearing wall	-/60/60	No loadbearing function
Loadbearing wall	60/60/60	All apply
Floor/ceiling assembly	60/60/60	All apply
Penetration seal	-/60/60	No loadbearing function
Door	-/60/30	No loadbearing function and insulation limited to 30 minutes
Door	-/60/- SM	No loadbearing function and no insulation but smoke seal required
Roller shutter	-/120/-	No structural support or insulation expected
Fire damper	-/120/120	No structural support
Fire damper	-/120/-	No structural support or insulation expected as combustibles are > 300 mm away
Lift landing door	-/60/-	No structural support or insulation expected

A smoke control door will have an SM added to the FRR, for example, -/60/30 SM. To comply with the SM classification, the door must be a fire door with smoke seals or solid cored (if timber cored, not less than 35 mm thick) fitted with smoke seals. There is no test for smoke leakage in C/AS1-7 Appendix C for smoke control doors.

A smoke separation (as defined in C/AS2-6), such as a wall or fabric material, has specific requirements. It must either be a smoke barrier complying with BS EN 12101-1:2005 *Smoke and heat control systems. Specification for smoke barriers*, or it must satisfy the following:

- Consist of rigid building elements capable of resisting without collapse a pressure of 0.1 kPa applied from either side and self-weight plus the intended vertically applied live loads.
- Form an imperforate barrier to the spread of smoke.
- Be of non-combustible construction or achieve an FRR of 10/10/-, except that non-fire-resisting glazing may be used if it is toughened or laminated safety glass.

A smoke separation may be assumed to be imperforate if, by visual inspection, there are no holes, gaps or openings that would permit the passage of smoke. Product manufacturers should be asked to confirm if their product or assembly meets the requirements of a smoke separation in other respects.

Walls surrounding a smoke control door must be a smoke separation.

Achieving approval of a fire-resisting construction

To obtain regulatory acceptance, evidence of performance must be submitted to the BCA.

Regulatory approval

Regulators should ensure the following:

- The standard to which the passive fire protection is tested or assessed is applicable (see section 4).
- The product is to be used as tested or assessed and documented - for example, when the product is to be used in a plasterboard wall, the document relates to identical construction. If there is any variation between the tested or assessed documentation, further evidence should be sought from a competent authority.
- The evidence provided is representative of the product(s) supplied.
- The document is:
 - a full test or assessment report (not a certificate), or
 - manufacturers' literature supported by a full test or assessment.
- If full specifications for passive fire protection systems are not provided with consent documentation, ensure there is a process in place for subsequent approval of the detailed specifications prior to fire separations and passive fire protection being installed in the building (see section 5).

The Institution of Professional Engineers New Zealand (IPENZ) Practice Note 22 (PN22) *Guidelines for Documenting Fire Safety Designs* gives information on documents to submit for a building consent.

Further information from IPENZ gives advice on professional services during the construction phase (CM1-CM5 for engineers). A BCA may request a producer statement PS3 (construction) and a PS4 (construction review) after the work is completed. A PS3 should use the sixth schedule of NZS 3910:2013 *Conditions of contract for building and civil engineering construction*.

Determining the performance

This is achieved by carrying out a test or obtaining an engineering evaluation of the likely performance of the passive fire protection system. The specification for any given passive fire protection system may not necessarily correspond to any one test report. It may have been derived from a collection of different test reports and engineering evaluations. The different types of documentation that may be provided are discussed below.

It is important to ensure that the intended use of the fire protection documentation is in accordance with the manufacturer's specification and installation instructions. Manufacturers or product suppliers must ensure all product specifications, technical literature and fire performance claims are supported by test reports, engineering evaluations or other relevant documentation.

Some reports may have stated periods of validity. For example, formal opinions issued in accordance with AS 4072.1-2005 on service penetrations have a validity limit of 10 years. Any reports outside their time limit should be referred to the sponsor of the report. Products should not be used until confirmation is received from the sponsor that the report remains valid and there have been no changes to the product since it was last tested or assessed.

The different types of common documentation are listed below. Designers may use any of the documents as an aid to selecting and specifying the appropriate passive fire protection systems. However, only the first five should be used to verify the FRR, to determine the correct installation requirements and as building consent or Code compliance documentation.

Fire test report

This is a detailed report prepared by a registered testing authority describing the tested specimen and results. It generally includes a full description, graphs, observations, results, FRR and direct field of application. The direct field of application states what variations can be made to the product that do not require referral to a registered testing authority.

Regulatory information report

A regulatory information report (as described in AS 1530.4-2005) provides the minimum information about a tested system required for regulatory compliance. It includes details of the fire test, the construction of the test specimen and results obtained. It should be prepared by a registered testing authority.

Assessment report or letter of opinion

Assessment reports are useful for extending the specification of a tested specimen (for example, to allow the dimensions of a component to be varied within stated limits). They may be necessary because it is not practical to include all possible minor variations in a component within a single fire resistance test. It is also usually not practical or necessary for all possible variations to be subjected to a separate fire resistance test. Assessment reports should be based on test results or by applying a relevant standard, calculation method or engineering principles, and this should be described in the report.

The report should include a statement similar to the following:

In our opinion and based on the information (provided by or contained within the following test reports) for the project, we believe the proposed passive fire stopping solution (design and installation details attached) will achieve at least a fire/smoke performance of when tested to standard

An assessment report should be signed/dated and should be prepared by an accredited fire testing laboratory or an independent third-party fire-testing expert acceptable to the BCA.

CodeMark certificate

A CodeMark certificate gives the stated performance of the passive fire protection and lists the NZBC clauses that apply. A BCA must accept a CodeMark certificate as evidence of compliance. CodeMark certificates must be carefully read to ensure that the product is used within the scope of the certification in relation to the applicable NZBC clauses and the level of performance. CodeMark-certified products have been assessed by an accredited product certification body.

Appraisal certificate

Various independent organisations produce documents ascribing conformity of a product to certain performance criteria - for example, BRANZ Appraisals. These are valuable documents in confirming the fire performance of a product or system. An appraisal should involve review of all the relevant reports and assessments by an expert. It may cover multiple NZBC clauses and will generally include processes to ensure quality control checks on the manufacture of the appraised product. A manufacturer's catalogue may also be reviewed as part of an appraisal, providing independent verification of the technical content of the catalogue.

Manufacturer's recommendation, data sheet, catalogue

A manufacturer's recommendation is generally linked to a specific form of construction that they are prepared to back with a warranty provided construction is in accordance with the detailed specification. However, a warranty should not be used as the sole means of verifying the performance of a building element. A manufacturer may provide catalogues and data sheets. These may contain references to test report, assessment or appraisal reference numbers and the organisation issuing these documents.

Test certificate

This may be only a single page and is used for marketing and initial verification of fire performance. It is not intended for regulatory acceptance or to give sufficient information for the construction of the specimen to be verified on site. The certificate may not give sufficient information for installation and should be used in conjunction with the manufacturer's full specification. This also applies to BRANZ type test summaries.

Changes to existing buildings

Existing buildings often present challenges in relation to the passive fire protection. For example, fire-stopping may be absent and difficult to retrofit, services may not be perpendicular to the penetrated element or the required clearances may not be present. Passive fire protection solutions appropriate for an existing building may differ from those required for a new build when consented alterations are being done. The full extent of any non-compliance may not be recognised at the outset of work being done and may only become apparent when passive fire protection features become exposed during the course of construction.

Under section 17 of the Building Act, new builds are required to comply in full with the NZBC, while an existing building that is subject to a building consent is required under sections 112 (alterations) and 115 (change of use) of the Building Act to be demonstrated to comply on an as near as reasonably practicable (ANARP) basis. Section 112 requires ANARP compliance only for the means of escape, while section 115 requires ANARP compliance for means of escape, protection of other property, structural performance and fire-rating performance.

An ANARP analysis is based on an evaluation of the sacrifices and benefits. The sacrifices are the tangible and intangible costs that the owner will meet in achieving certain benefits. This can include things such as the direct cost of installing a sprinkler system. The benefits can be expressed and evaluated in terms of reduced fire safety risk. This means that, in an existing building, if full compliance can be achieved without too much cost (financial/disruption/damage), that should be the aim. Where this cannot be achieved or where the cost far outweighs the benefit of achieving full compliance, an ANARP solution may be applied. It is not always cost-effective, timely or serviceable for bespoke fire tests or assessments to be undertaken for every situation where, due to historical existing on-site conditions, a fully tested and compliant solution is difficult to demonstrate or install. In these cases, the advice of the product manufacturer or a competent authority should be sought.

An ANARP application should clearly describe the sacrifices and benefits, justify the data used and the assumptions made, be risk based and ideally include a sensitivity analysis. It might also show the various combinations of sacrifice and benefit that are possible for the design.



PARTICIPANTS AND ROLES

Ensuring passive fire protection is correctly and effectively specified, procured, installed and maintained involves several processes and the active involvement of several participants. The architect/lead consultant should arrange for coordination between participants so that building service runs and potential penetration of fire separations are identified and minimised at an early stage in design.

Figure 4 lays out a typical process for a project, from developing the project scope and establishing the requirements to be met, to gaining consent, construction, inspections and sign-off. Two paths are shown for the specification and approval of the passive fire protection design.

The preferred path is that the complete specification and documentation of all the passive fire protection products and systems are submitted to the BCA at the building consent stage. This approach reduces the potential for later conflicts during construction and installation, which in some cases can lead to project delays and/or rework.

An alternative path, which may be necessary for some building projects, involves the use of performance specifications for passive fire protection systems, where the final selection of products may not be known until after the consent is applied for and the tender process is completed.

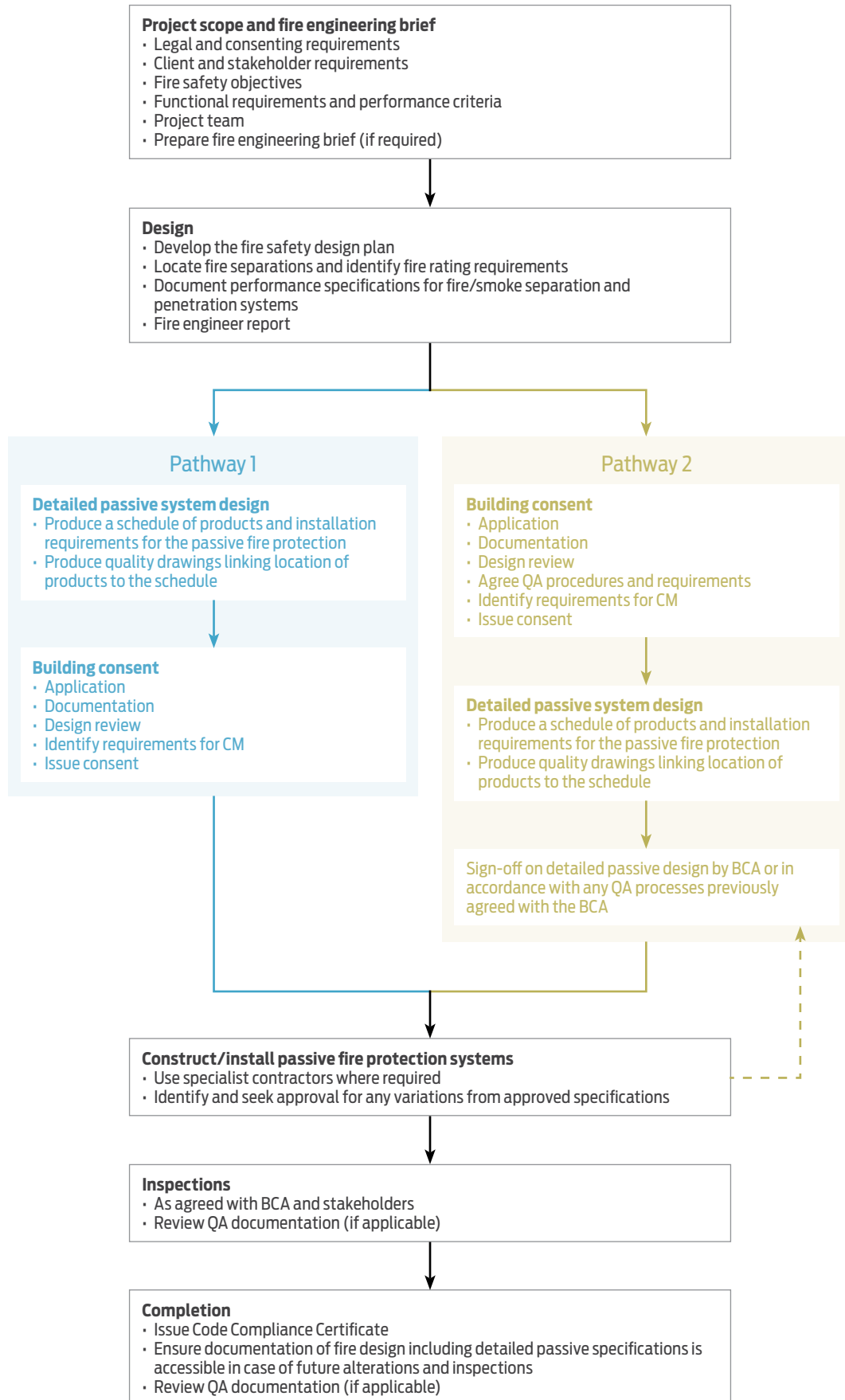

Figure 4. Typical project process for passive fire protection, showing two paths for specification and approval

While commonplace, the lack of passive fire protection design details and product selection at an early stage in the design and construction process has contributed to widespread problems with passive fire protection quality. These problems typically come to light when it is discovered that there are no suitably approved assemblies available that meet the performance specification for the intended construction. This has in the past led to the use of untested assemblies of unknown performance, and this practice is strongly discouraged. While full details may not be practical, generic passive fire protection details should at least be generated at an early stage to identify any areas of concern.

Therefore, when performance specifications are being submitted to the BCA at the time of building consent, it is essential that the follow-up detailed design, specification and approval of those passive fire protection systems be done before the construction of fire separations in the building commences.

Following the appointment of the contractor and installers, further coordination and discussion will be required. Key topics that should be discussed are who is taking responsibility for the passive fire protection, confirming what systems are being used and whether there are any special requirements. This should generally be done at the first subcontractors meeting.

Designer/architect/engineer

The designer/architect/engineer must correctly specify the passive fire protection. The performance specification based on the overall fire design will be given in the fire report and consent documentation. Correct selection and specification of the individual passive products and systems requires knowledge and understanding of passive fire protection principles and practices. Correct specification includes understanding the test reports, evaluations and any limits of applicability. For example, penetration seals tested in a concrete wall require separate verification for installation in a framed wall lined with plasterboard.

The design team must ensure the following:

- Detailed plans of the building are produced with the size and position of all services including ducts, cables, pipes penetrating fire walls and floors.
- The fire engineer's specification and details are incorporated into the overall design as part of the building consent application.
- The placement, size and type of passive fire protection are specified using clear, standardised symbology (for example, NFPA 170 *Standard for fire safety and emergency symbols*).
- The space to be left around penetrating items, where appropriate, to allow fire stopping to be installed, inspected and maintained is appropriately specified.
- Detailed specifications and drawings for all situations that vary from test standards are provided or obtained.

The members of the design team will depend on the complexity of the project. For simple projects, the same person may perform more than one role. For larger projects, a fire engineer will develop and document the basis for the fire design. The structural engineer will ensure the building design will comply with clauses B1 and C6 of the NZBC. They will rely on the fire engineer to identify the fire loads and level

of fire performance required to be met by the building structure and will identify the building structural members required to be protected. The fire engineer will work with the architect to identify firecells and escape routes and the location of fire separations. The building services engineer will design, specify and document the building services required and coordinate their routing with the rest of the design team.

A member of the design team (often the fire engineer) may be involved at different stages in ensuring that the installation of the passive fire protection has been correctly achieved. This will depend on the terms of contract for the person and the requirements of the BCA. Some BCAs require construction monitoring to be done to ensure the correct installation of the passive fire protection.

If the design team member is required to provide construction monitoring and sign-off (such as providing a PS4, for example), they must:

- review all consent issue documents and provide a design coordination statement (for example, as per IPENZ PN22)
- carry out any construction monitoring that may be required as a condition of consent (for example, CM3).

Building consent officer/building inspector

The building consent officer has to be aware of the documentation (test reports, certificates, installers' declarations and so on) necessary in establishing the performance of passive fire protection. This is so they can be sure the correct documentation is supplied to demonstrate compliance with the appropriate standards.

The person doing the inspection must be familiar with the types of passive fire protection being used so they can be sure the elements are installed correctly and take note when any substitutions or variations take place. The building consent officer should be alerted to any substitutions or variations.

The BCA may accept producer statements to assist in deciding whether it is satisfied on reasonable grounds that the provisions of the NZBC will be met and whether the building work is completed in accordance with the plans and specifications. BCAs should use their judgement when considering producer statements and how much weight to give them. When considering whether to accept a producer statement, the BCA should assess the credentials of the author to ensure they have the appropriate experience and competence. BCAs should make their own inspections of the building work.

The BCA is responsible for:

- approving passive fire protection systems to be installed and approving any variations that may later become necessary
- ensuring work done throughout the installation process is inspected so that any unacceptable work or disputed solutions are quickly identified.

Project manager/head contractor/installer

The project manager, head contractor and installer play a crucial part in ensuring that the passive fire protection will be an effective barrier to fire. They must understand the importance of correct installation and be able to rectify and know when to seek further advice on any problems with the installation.

The head contractor must:

- ensure all passive fire protection is installed as designed
- ensure passive fire protection and other construction is not placed in positions that would disrupt or prevent installation of other passive fire protection such as services and penetration seals
- ensure passive fire protection already installed is not damaged by further installation work
- sequence work to allow passive fire protection to be installed as specified, providing access, space to work and adequate time to source and install products and inspect assemblies while they are accessible
- agree the inspection and sign-off processes
- arrange regular inspections by the BCA (and design engineer if necessary for the consent conditions to be met if it is part of the design team's contract) of work done so that any unacceptable work or disputed solutions are immediately recognised.
- document and tag/label, where appropriate, all passive fire protection.

The situation on site may change rapidly, so the head contractor needs to be aware of changes and how they affect the passive fire protection. Specific passive fire details of construction may not be on fire or architectural drawings. The head contractor may also be responsible for researching and procuring the passive fire protection systems. They need to provide evidence to prove that the systems installed are compliant.

A common cause of non-compliant systems occurs when research and procurement of passive fire protection systems is left to the head contractor when there are no approved systems available at the outset. It is imperative that, if specification of passive fire protection systems is left to the contractor, passive fire protection requirements are clearly communicated to the contractor in the design documentation.

Ideally, specialist installers with detailed knowledge and familiarity with the products should be used whenever possible. This is particularly desirable in the case of fire doors (which are required to have labels), lift landing doors, roller shutters, spray or intumescent paint coatings for structural steel protection and fire dampers. Fire stopping may also be applied by specialist installers, but this may not always be the case. Where there are complex fire-stopping issues, using a specialist designer or installation contractor is strongly advised.

Independent qualified person

The independent qualified person (IQP) has an important role in maintaining the effectiveness of passive fire protection by noting any defects during building warrant of fitness (BWOFF) inspections as per the building's compliance schedule. Fire engineers can assist the role of the IQP by supplying FRR/separation location drawings to go with the compliance schedule. However, obtaining access to thoroughly inspect fire separations that are hidden behind other building components may be unreasonable, so it should not be expected that a BWOFF is a guarantee of full passive fire protection compliance in the building. This is also a reason why thorough documentation and inspection is critical during construction or modification work when the passive fire protection features are exposed.

Third-party inspector

The third-party inspector (such as an IQP, independent consultant or fire engineer) may be called on by the owner, project manager or local authority officials to carry out an inspection of passive fire protection. They must understand the issues of passive fire protection.

Table 2 provides a summary of the key roles and responsibilities.

 Table 2. Summary of roles

Designer/architect/engineer	Specify FRR Specify products Clearly communicate requirements to other parties Construction monitoring Sign off installation (PS4)
Building consent officer/building inspector	Ensure documentation is appropriate for application
Project manager/head contractor/installer	Correctly procure and install passive fire protection products appropriate to the application Sign off installation PS3 (or LBP memorandum)
Independent qualified person	Note any variations during annual inspection
Third-party inspector	Ensure passive fire protection is correctly installed Sign off installation

General requirements of participants

All parties involved in installing passive fire protection must understand the processes appropriate for their role in the project. This may include:

- designer/architect/engineer, BCA and inspectors knowing the fire resistance rating requirements derived from the NZBC and the fire design and providing clear and explicit communication of the fire protection requirements to other parties
- suppliers and installers knowing the appropriate specifications and standards to be used and clearly labelling passive fire protection features as required
- understanding the appropriate use of passive fire protection systems - for example, doorsets approved for use in the appropriate type of wall construction
- specifiers and BCA understanding manufacturers' literature and being satisfied that the supporting documentation demonstrates compliance with the required specifications and standards
- seeking further advice for complex installations when necessary, including recognising and deferring judgement of non-approved assemblies to competent authorities
- undergoing suitable instruction or attending education courses on the installation of passive fire protection.

Ensuring that the installation has been carried out correctly is not solely the responsibility of the person carrying out the installation. Other participants involved in the process can verify that the installation is correct.

Training

Some manufacturers offer training in installation of their products, but this is not widespread. The New Zealand Qualifications Authority (NZQA) has these qualifications on passive fire protection:

- National Certificate in Passive Fire Protection (Building Consent Inspections) (Level 4).
- National Certificate in Passive Fire Protection (Routine Inspections) (Level 3).

Courses for these qualifications are run by industry training organisation Competenz. Some organisations such as BRANZ and BOINZ may offer short courses on passive fire protection and NZBC matters.

These are not mandatory but may give useful information to those new to the passive fire protection industry.

This does not preclude experienced and competent persons who have not attended such courses from providing advice on passive fire protection.



6

ON-SITE INSTALLATION

Attention to detail and installation quality is essential for the passive fire protection to perform its function.

Consented documents

Once the consent documentation has been provided and a building consent has been issued, passive fire protection must be installed as specified in the consented documents and in accordance with any agreed quality assurance processes. This means in accordance with all supporting information supplied to the BCA, including manufacturers' instructions.

Where a performance specification only has been submitted in consent documentation, the subsequent process needs to be agreed with the BCA to ensure the selection and installation of the passive fire protection system will comply with the NZBC.

Any deviations from the consented documents or design specifications, such as a substitution of materials or components, must be approved via a consent amendment by the BCA before the change is made. This is to ensure that Code compliance is not compromised by the proposed change. The BCA documents and records the change(s) if approved.

It is important that the passive fire building elements are installed in accordance with the consented documents and with any agreed quality assurance and product approval processes that may be needed after the consent is issued.

Documents that should be available to those involved with the installation of passive fire protection are:

- drawings/specifications clearly identifying the location of fire-rated construction
- product specifications for the passive fire protection.

A copy of the consent documents (plans, technical literature and specifications) covering all aspects of passive fire protection must be held on site and be available for use by the contractors carrying out installation work and by the work supervisors and BCA inspectors. Any approved amendments to the consent must also be available.

Specialist installation contractors

Specialist contractors perform the important functions of installing and inspecting passive fire protection. Ideally, passive fire protection should be installed by specialist installers. They have experience in their particular systems and can help ensure compliance and quality in the final product.

This is especially the case for fire doors that are required to have labels, penetration seals, lift landing doors, roller shutters, fire dampers and structural steel protective coatings such as sprayed cementitious or intumescent paint.

While a system as straightforward as a plasterboard fire-rated wall may not seem to require a specialist for installation, there are many parts of the task that, if not correctly done, can result in a substandard installation. For example, increasing fastener spacing from the specification of fixing spacing can render the system non-compliant. In these cases, a specialist contractor with experience of installing fire resistance rated systems would improve confidence that the systems are compliant.

Substitution or hybridisation

At some point in the building construction process, specific system components will be identified in various documents. This can be at the original design stage or when the contractor has selected the appropriate systems.

In general, substitution of passive fire protection systems, whether components within a system or the complete system, is not an acceptable practice as it has the potential to negate the performance of the installed element. A deviation from the design can be a necessary substitution where a system or material has become unavailable in the time between issuing the building consent and actual construction on site. If substitution cannot be avoided, the whole system may be substituted for another, or just a component of the system may be substituted. In both cases, the documentation needs to be amended and submitted to the BCA for prior approval.

Where individual components are substituted, there is greater difficulty in determining the fire resistance rating, as each passive fire protection system is specific to a manufacturer (other than concrete, masonry and some solid timber products), and approval may be difficult to achieve. This is why leaving passive fire component specification until late in the process is discouraged.

A manufacturer may be prepared to accept the substitution but may require it to be reassessed as a fully compliant system before approval is sought from the BCA. An

example is where a plasterboard wall has been installed as part of one manufacturer's system but using another manufacturer's board. The manufacturer of the substituted board may not have that particular system validated but may choose to do so through an assessment from a competent authority or individual capable of providing such assessments.

Where such deviations have been approved or will require further assessment, the specialist contractor, consultant or third-party certifier should be aware of this. Where the substitution cannot be resolved by assessment, a fire test may be required or an alternative compliant system needs to be installed.

On-site supervision

On-site supervision of the installation is recommended from the first arrival of the products to site to final sign-off. This requires either training of on-site staff or employing third-party inspectors as discussed above. These parties can then identify any defects and report them to the architect, designer and BCA for action. At this stage, the earlier the defect is identified, the easier it is to fix and the less delay there will be to the project.

Any deviations from the design specification can have impacts on the project, not the least of which is a delay in completion. For example, a fire resistance test may take 3 months to schedule and complete or 3-4 weeks for an assessment, so it is important that the installation is correctly installed first time.

Documenting the installation

During the installation, appropriate documentation should be maintained and stored in an accessible manner. These documents can be hard copy (paper) or electronic. The documentation should be maintained so that any changes to the installation and products are recorded and accessible for future modifications.

The installer may be the person actually carrying out the work or a representative of the company installing the systems such as the builder or project manager.

Once installation has been completed, the installer should provide the following information:

- A plan showing the location of passive fire protection - either mark up existing plans, such as those provided for consent, or create new plans.
- A list of passive fire protection and the identities of the products used.
- A declaration that the passive fire protection has been installed in accordance with the manufacturer's specifications.
- PS3 for construction.

Figure 5 and Table 3 below show an example of a plan and a schedule for penetration seals. This type of documentation can be helpful for obtaining a Code Compliance Certificate and would also be useful in future when changes are made during a refurbishment or when new pipe and cabling systems are installed, affecting fire separations.

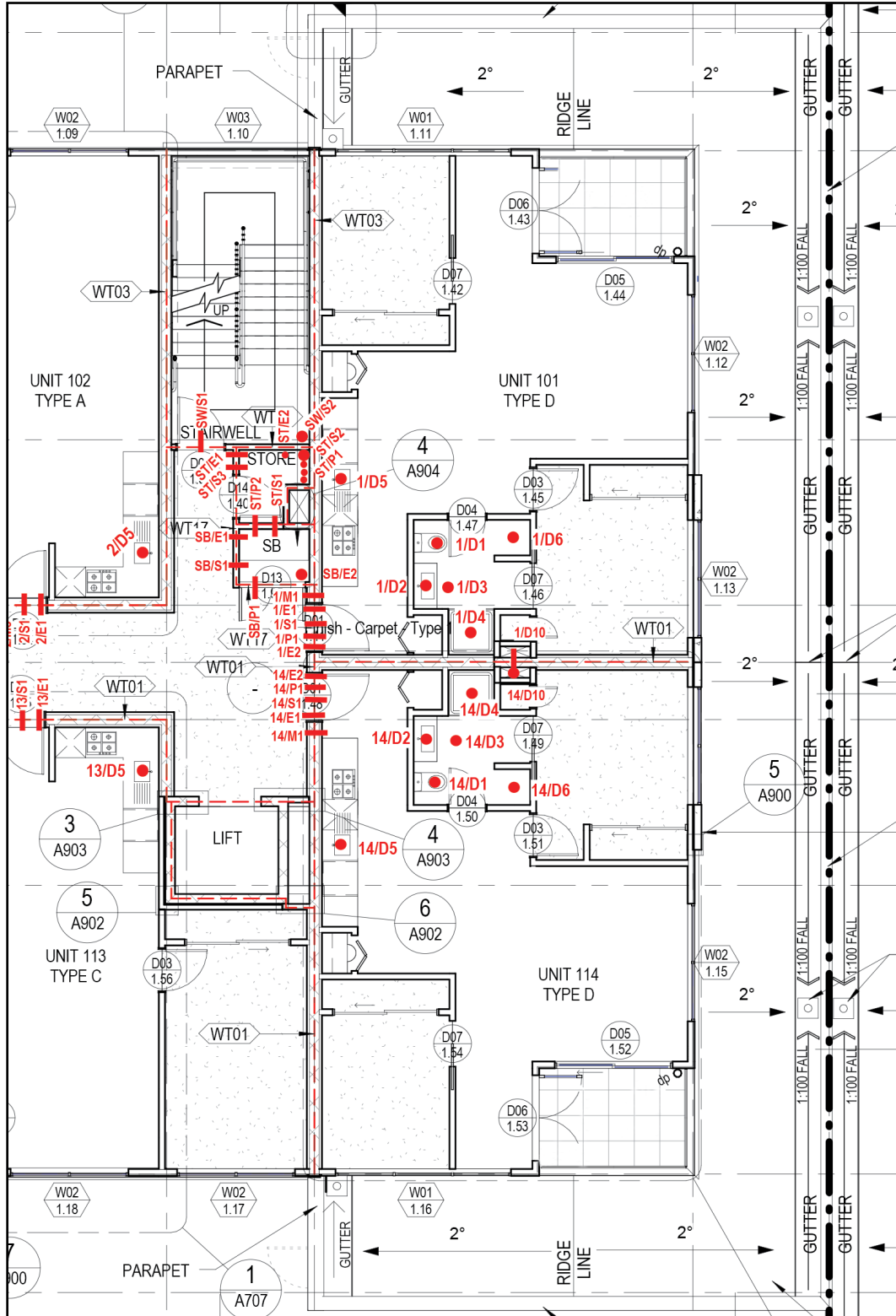

Figure 5. Example of plan of penetration seals

Table 3. Example of a passive fire protection schedule

FIRE PENETRATION SCHEDULE				DATE: JULY 2016		
Project name		Pyro Apartments				
Project address		Firehouse Lane, Fawkes Bay				
Consent number		BE – 1234567/1				
Level 1, Unit 1						
INSTALLATION REF	SEPARATION	PRODUCT USED	FIRE RATING (MINUTES)	SERVICE DESCRIPTION		
UNIT #	SERVICE #					
Drainage						
101	D	1	Floor	FireAway pipe wrap	-/120/120	100 mm (WC)
101	D	2	Floor	FireAway pipe wrap	-/120/120	40 mm (WHB)
101	D	3	Floor	FireAway pipe wrap	-/120/120	40 mm (FWG)
101	D	4	Floor	FireAway pipe wrap	-/120/120	40 mm (shower)
101	D	5	Floor	FireAway pipe wrap	-/120/120	50 mm (sink)
101	D	6	Floor	FireAway pipe wrap	-/120/120	40 mm (WM)
101	D	10	Block wall	FireAway pipe wrap	-/120/120	100 mm drain
Sprinklers						
101	S	1	Block wall	Ashes 'NoFlame'	-/60/60	25 mm diameter steel sprinkler pipe
Water supply						
101	P	1	Block wall	FireAway fire collars	-/120/120	25 mm hot and cold water supply (2 No.)
Mechanical						
101	M	1	Block wall	BlazeGo XYZ sealer	-/120/120	150 mm supply – fire damper
Electrical/data and fire alarm cabling						
101	E	1	Block wall	PyroSeal ABC silicone	-/30/30	power and alarm cables
101	E	2	Block wall	PyroSeal ABC silicone	-/30/30	data cables
Note: Products listed are for illustrative purposes only and are not actual products.						

Labelling

It is good practice for service penetrations and control joints to be clearly labelled and marked with information that includes the FRR, name and contact details for both the installer and manufacturer, installation date and unique reference number for the installation. The label should ideally be positioned close to the service penetration, seal or control joint. An example label is given in Checklist 6 for a penetration seal (see section 8).

Where fire-resistant doorsets are required to meet NZS 4520:2010, they must be provided with permanently fixed labels. See Checklist 2 in section 8 for an example.

Code Compliance Certificate

At the completion of a project, on application by the owner or their agent, the BCA will issue a Code Compliance Certificate (CCC) if it is satisfied on reasonable grounds that the building work complies with the building consent. When carrying out a final

inspection for a CCC, a BCA needs to be satisfied that the work on site accurately reflects what was approved in the building consent documents and is in accordance with any subsequent process put in place when only performance specifications were included in consent documentation. The BCA can do this by carrying out its own inspections or by accepting producer statements or other documents from the building owner or approved installer. It may also be necessary to provide any certificates from licensed building practitioners if the work requires this. At the time of publication, there was no legal requirement for a licensed building practitioner to install passive fire protection.

Fire and smoke separations are specified systems and are required to appear on a compliance schedule if other fire safety specified systems are installed within the building. Compliance schedule statements are issued with the CCC by the BCA. However, it is the owner's responsibility to identify the specified systems in the building when applying for the building consent. Note that the inspection, maintenance and reporting requirements of specified systems must be part of the documentation submitted for consent. Building owners should also ensure that plans identifying the location and fire resistance requirements of fire separations are available to IQPs and others involved in maintenance or inspection during the life of the building.

Ultimately, it is the building owner's or their agent's responsibility to ensure that the passive fire protection, amongst other matters, complies with the building consent. Given the difficulty of inspecting concealed service penetrations, it is essential that these are installed correctly and inspected at the appropriate time and that adequate documentation is recorded. The BCA will issue the CCC only when satisfied on reasonable grounds that the building complies with the consent (and the NZBC).

Verification of performance

The verification of the performance of passive fire protection is an important part of the final sign-off and starts at the design stage, where the correct specifications and identification of the passive fire protection are made on any initial plan. This may extend to a separate fire protection plan being provided if the building is complex. Otherwise, passive fire protection can be included in a general building plan.

Documents necessary for the verification of installed passive fire protection start with the passive fire protection plan (or building plan, if passive fire protection is included).

The basic documents are:

- fire and smoke compartment plans (from fire engineer)
- site installation specifications (from architect or building services)
- product specifications/certificates/reports or other documents such as a letter of opinion or assessment from a competent authority.

Retrofit or renovations

When any additional work is carried out, it is important that the original passive fire protection is not changed or affected. Also, any repairs or improvement such as increasing the fire rating must be with compatible products. Examples include:

- replacing fire door and fire-rated lift landing door hardware - identical product or approved by the manufacturer
- adding cables or pipes through fire walls - finish penetration with approved seals
- repairing damage in plasterboard walls - stud to stud patching.



7

SPECIFIC INSTALLATION REQUIREMENTS

Examples of installation procedures for each type of passive fire protection are given in the following sections. All passive fire-stopping products are tested and approved as a system, and the use of incorrect and untested fixings can severely compromise the rating achieved by the system.

The checklists in section 8 indicate the key installation requirements that the installer, site supervisor and BCA inspector need to be aware of. Checklists can also be developed or adapted for other aspects of passive fire protection. While the checklists could form part of the Code Compliance Certificate application, they are not intended as a substitute for the full fire specifications or authority requirements, nor do they cover general site procedures or coordination of trades.

Note: Standards referenced in the checklists are those applicable to C/AS1-7. They may also apply to Alternative Solutions but, in that case, are not mandatory. Means of compliance will depend on what was provided in the building consent documentation.

Fire protection coatings

Typically cementitious or intumescent coatings. These can have several purposes:

- Control fire spread over surfaces to meet surface finish requirements.
- Increase the fire resistance ratings of doors and walls.
- Provide a fire rating to structural steel.

All require specialist application to ensure adequate preparation of the substrate for correct coating adhesion and to control coating thickness to meet the manufacturer's specifications.

Coatings for structural steel

- These provide a means of achieving structural adequacy requirements without encasing the steel in concrete or fire-rated board systems.
- Thin-film intumescent coatings can be solvent or water-based. They are most suitable for interior use.
- Thick-film intumescent coatings are typically epoxy based. Due to their toughness, they are used in environments exposed to the weather or where access for future maintenance is difficult.
- A quality assurance plan should be in place stating the detailed inspection requirements.
- Application contractors should provide evidence of their knowledge and be competent in meeting the requirements of the coating manufacturer.
- Coatings must be applied strictly in accordance with the manufacturer's specifications including surface preparation, application and ambient conditions as specified.
- Base coat thickness should be measured both when wet and dry to ensure the required thickness is achieved.
- Records should be kept of materials used including batch numbers, environmental conditions at the time of application, steel preparation and thickness of applied coatings.
- The application contractor should ensure records are retained and provided to the building owner or their agent on completion of the work.

Sealing penetrations

Various options are available for sealing penetrations. They will depend on the type of penetration and include the following common types.

Collars - used for plastic pipes

- Applied on both sides of a wall or underside of a floor.
- On walls, will be surface fixed using suitable fixings such as masonry anchors, laminating screws and expanding metal hollow wall anchors as appropriate to the wall.
- On floors, will be either surface mounted to the underside and fixed using masonry anchors, cast-in or drop-in from above and fixed to the upper surface of solid floors. At the date of this guide, no approved penetration seals all the way through cavity floor/ceiling systems are available in New Zealand.
- Only fixings stated in the appropriate documentation should be used to secure a collar in place. Different-sized collars have a minimum size fixing.

Wraps - used for plastic pipes

- Use similar intumescent materials to collars but do not have a steel case.
- For masonry/concrete construction, the wraps fit round the pipe and are inserted in the hole in the wall.
- When used with plastic pipes in hollow construction, a steel sleeve must be fitted in the wall.

Sealants - used as gap sealant and filler around other systems, metal pipes

- Essentially two types: intumescent and non-intumescent.
- Used to seal gaps around walls, linear gap (building joints), fillers around other penetration systems, such as pillows, fire barriers, cable trays, bunched and individual cables.
- Use is specified by a maximum width and minimum depth of sealant.
- In sheet lining systems, the depth of the sealant is dictated by the thickness of the layers, and patching may be required to bring the linings up to the specified thickness or reduce the gap width (see below for further comments on patching).

Pillows, fire-rated mortars - used for filling large apertures

- Used to fill large apertures in floors and ceilings.
- Also require a sealant.
- Fire-rated mortars in floors may not be trafficable so safety barriers may be required to eliminate foot traffic.

Fire barriers - used for pipes and cable penetrations

- Can be a thin fabric or a thick mineral fibre slab.
- Used to fill large apertures.

Expanding PU foam

- Mostly used as a gap fill or backing material for other fire-rated systems.
- Some expanding PU foams may fill larger spaces and have intumescent properties.

Box and foam cable transits

- Essentially a steel box containing intumescent material with flexible PU foam sides. The cables pass through this (see Figure 29).
- Cables can be removed or added without affecting the fire rating.
- Foam on its own as a fire barrier is also available.

In all cases, the manufacturer's specifications must be followed, paying attention to the specific application, wall type and fixing methods. Wall lining thickness may affect the FRR, and additional patches of lining may need to be applied. Patching should make up the thickness of the wall to that specified by the manufacturer. The patch, when required, should be securely fixed to the wall and preferably to framing members.

New passive fire protection products become available all the time, so users must keep up with the latest developments to see how they may be able to include them in their work.

Passive fire protection systems - index

//// Passive fire protection systems

PASSIVE FIRE PROTECTION SYSTEM	PAGE NUMBER
Walls - framed	34
Walls - masonry	35
Walls - composite	36
Cavity barriers	37-39
Doors	40-45
Shutters	46
Ducts	47
Fire dampers	48-50
Structural fire protection	51
Intumescent coatings	52
Linear gap seals	64

//// Penetrations by type

PENETRATIONS BY TYPE		SOLID CONSTRUCTION PAGE NUMBER	HOLLOW CONSTRUCTION PAGE NUMBER
Electrical and information technology	Single cables	53	53
	Multiple cables	54-55	54-55
	Cable trays	56	56
	Box penetration cable transits	57	57
	Pillows	58	58
	Power outlets	59	59
	Downlights	60	60
Plumbing	Plastic pipes/collars	61 and 63	
	Metal pipes	62-63	62-63

Walls - timber-framed (single or multi-layers)

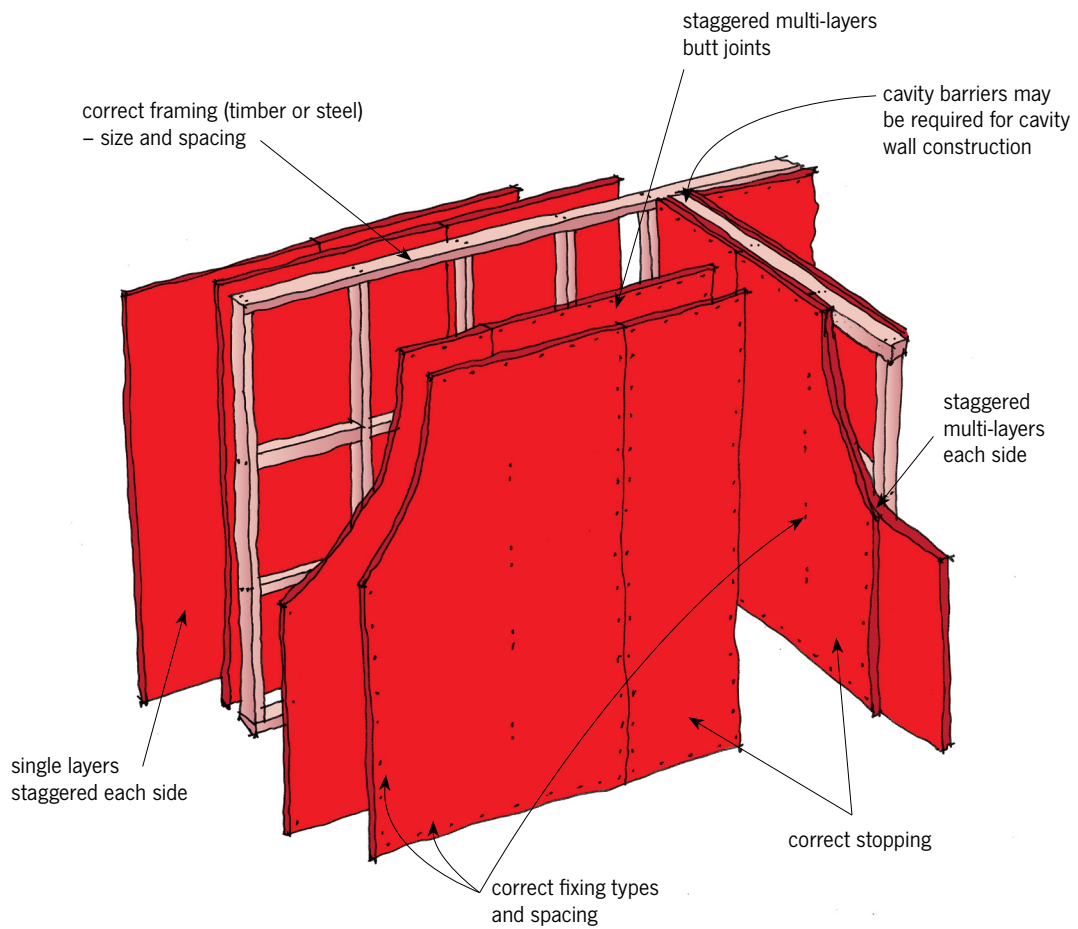

Notes

- Follow manufacturer's specifications
- Obtain data sheets, catalogues etc.
- Screw or nail fixed
- External wall will need cavity barriers at firecell junctions

Figure 6. Typical framed wall features

Walls - masonry

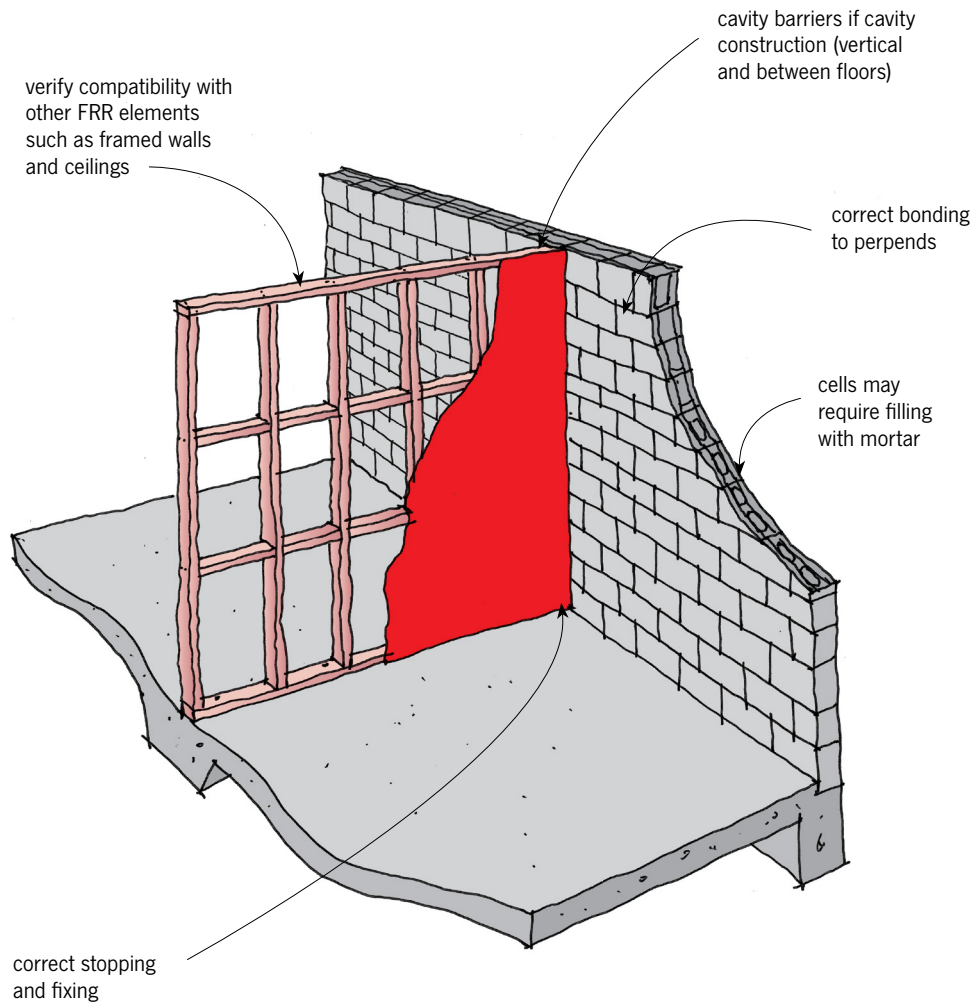

Notes

- Follow manufacturer's specifications
- Obtain data sheets, catalogues etc.
- External wall will need cavity barriers at firecell junctions
- Ensure different wall systems are compatible

Figure 7. Typical block wall features

Walls - composite

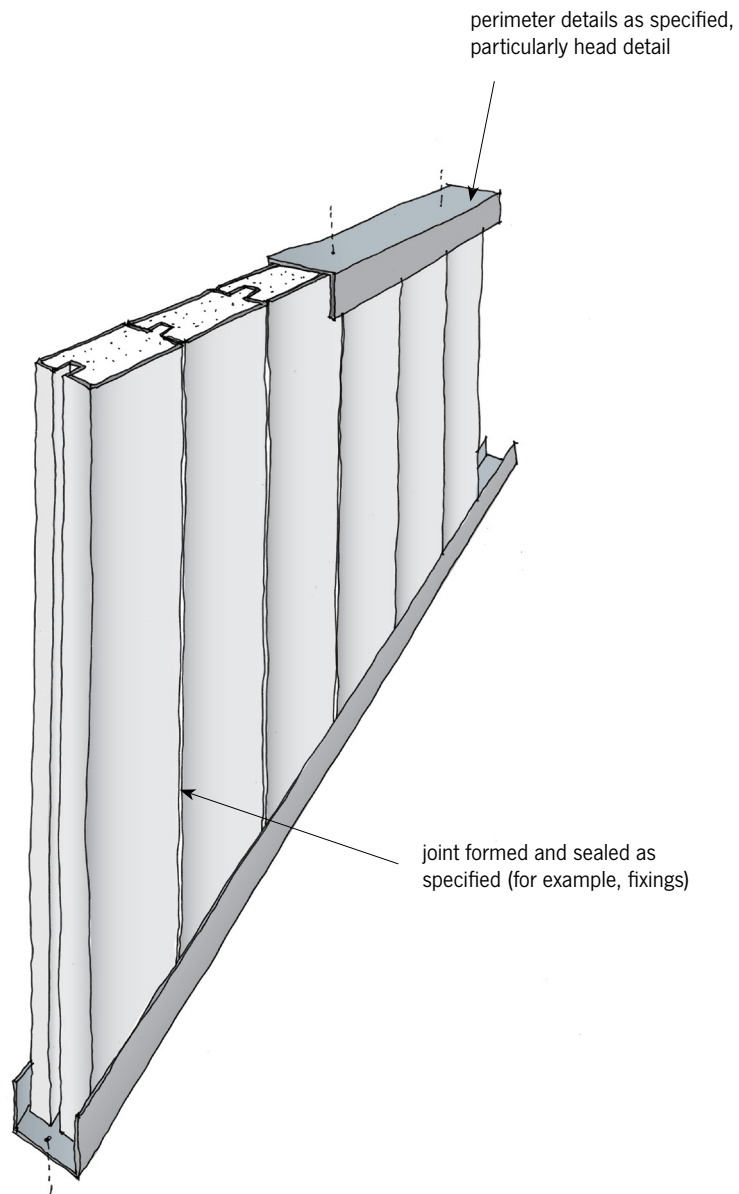

Notes

- Follow manufacturer's specifications
- Obtain data sheets, catalogues etc.
- All joints to be as specified by manufacturer – may require mechanical fixing
- Ensure correct FRR is obtained, especially insulation

Figure 8. Typical composite wall features (for example, foamed plastics, cement, mineral wool sandwich panels)

Cavity barriers

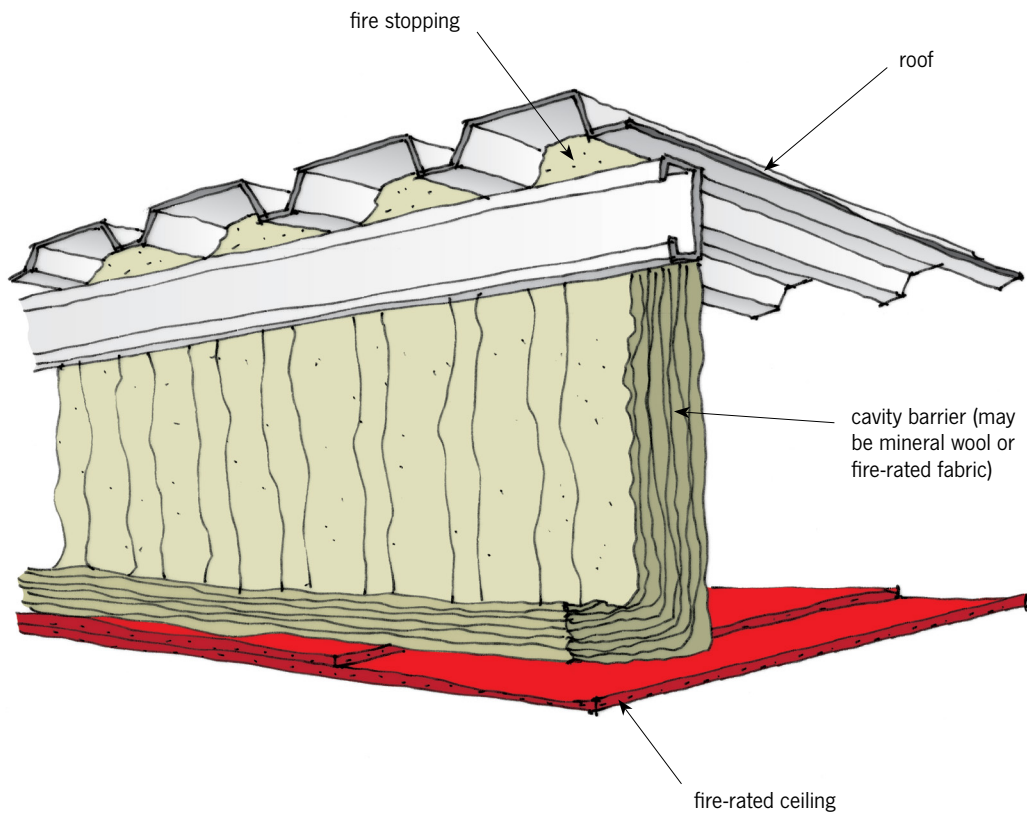

Notes

- Follow manufacturer's specifications
- Obtain data sheets, catalogues etc.
- Used for roof spaces, end floor slab/curtain walls, at roof/top of wall junctions, within hollow walls such as external walls
- Cavity totally sealed – no gap
- Mineral wool strips and blankets, fire-rated fabrics

Figure 9. Vertical cavity barrier in ceiling space

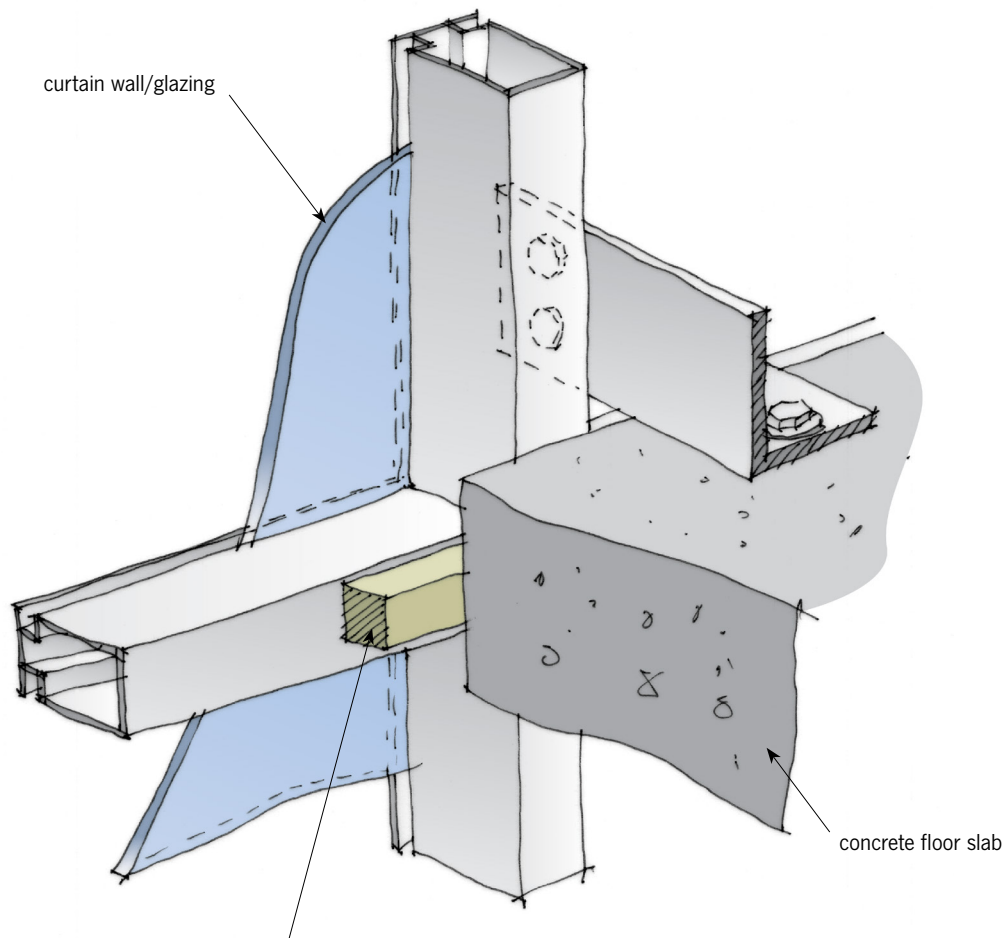

cavity barrier (for example, compressed mineral wool), may require additional support such as metal clips, must fill the gap

Notes

- Follow manufacturer's specifications
- Obtain data sheets, catalogues etc.
- Used for roof spaces, end floor slab/curtain walls, at roof/top of wall junctions, within hollow walls such as external walls
- Cavity totally sealed – no gap
- Mineral wool strips and blankets, fire-rated fabrics

Figure 10. Cavity barrier – floor edge to curtain wall

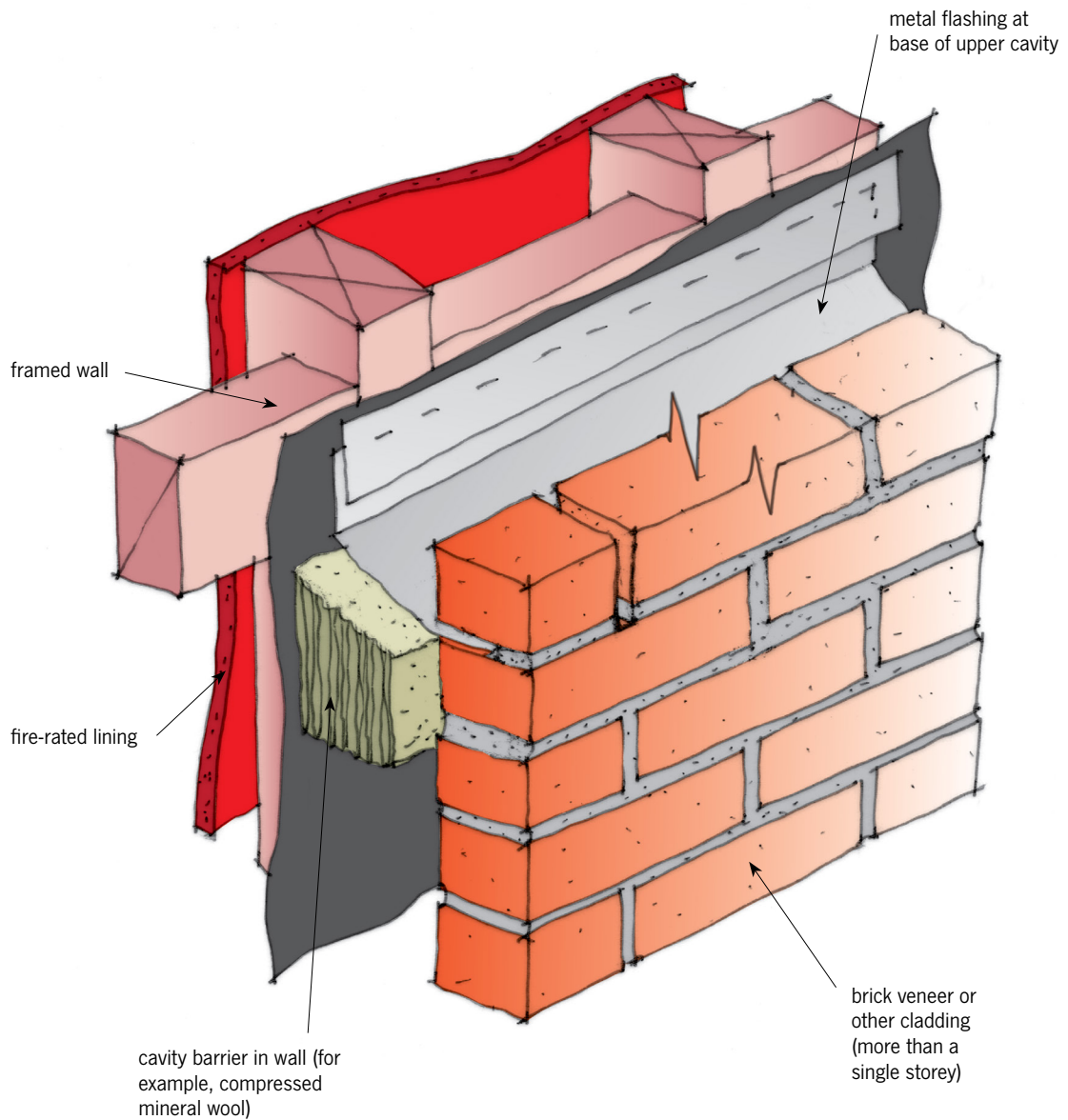

Notes

- Follow manufacturer's specifications
- Obtain data sheets, catalogues etc.
- Used for roof spaces, end floor slab/curtain walls, at roof/top of wall junctions, within hollow walls such as external walls
- Cavity totally sealed – no gap
- Mineral wool strips and blankets, fire-rated fabrics

Figure 11. Cavity barrier in taller wall

Doors - doorsets

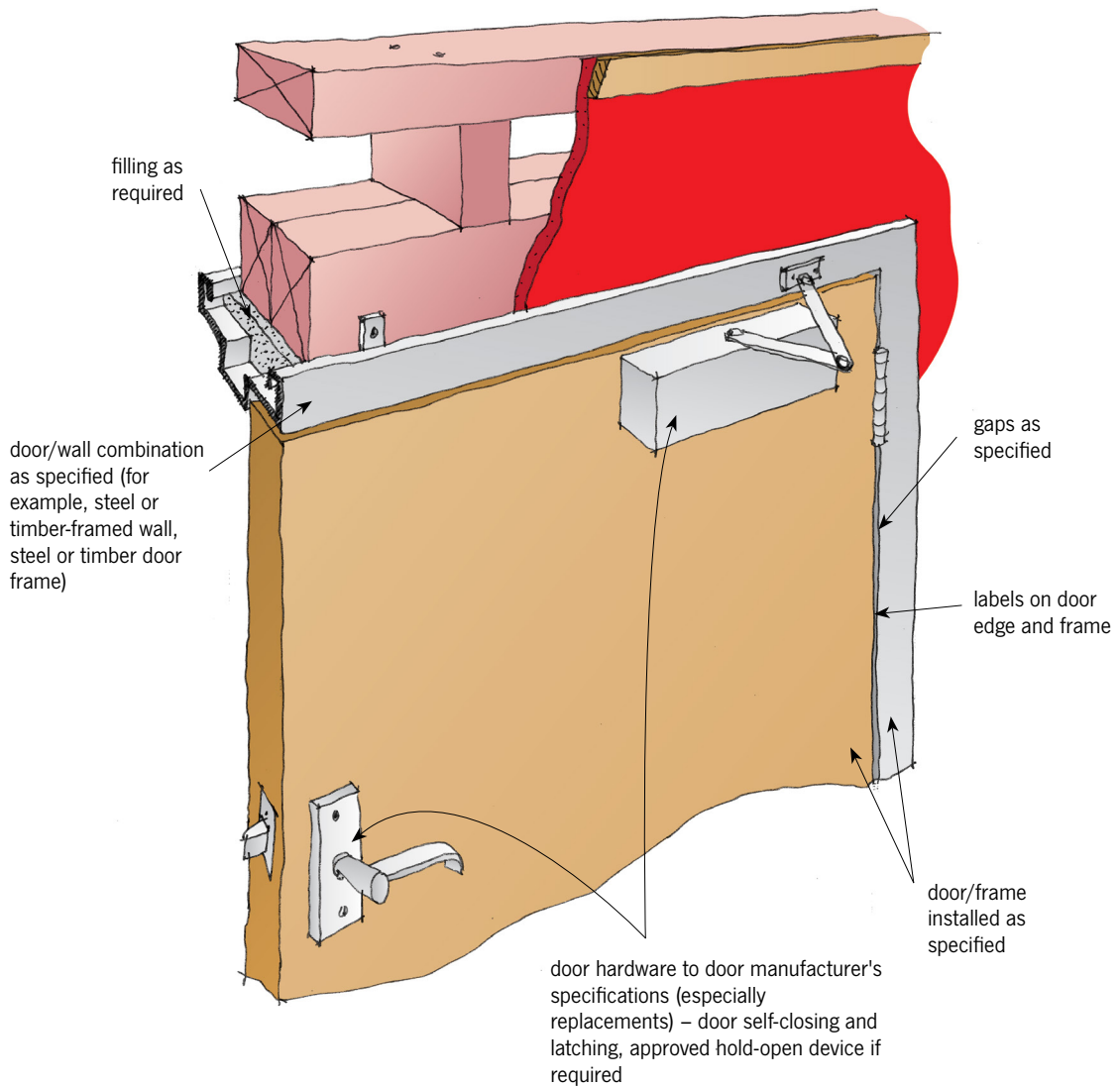

Notes

- Follow manufacturer's specifications
- Obtain data sheets, catalogues etc.
- Frame fixing as specified by manufacturer
- Hollow steel frames filled as specified by manufacturer
- Gaps to edge of frame typically 3 mm
- Door stops typically 25 mm thick but may vary
- Ensure compatibility of door and wall as specified by manufacturer
- Labels required on door edge and frame

Figure 12. Typical doorset features – timber-framed wall and steel door frame

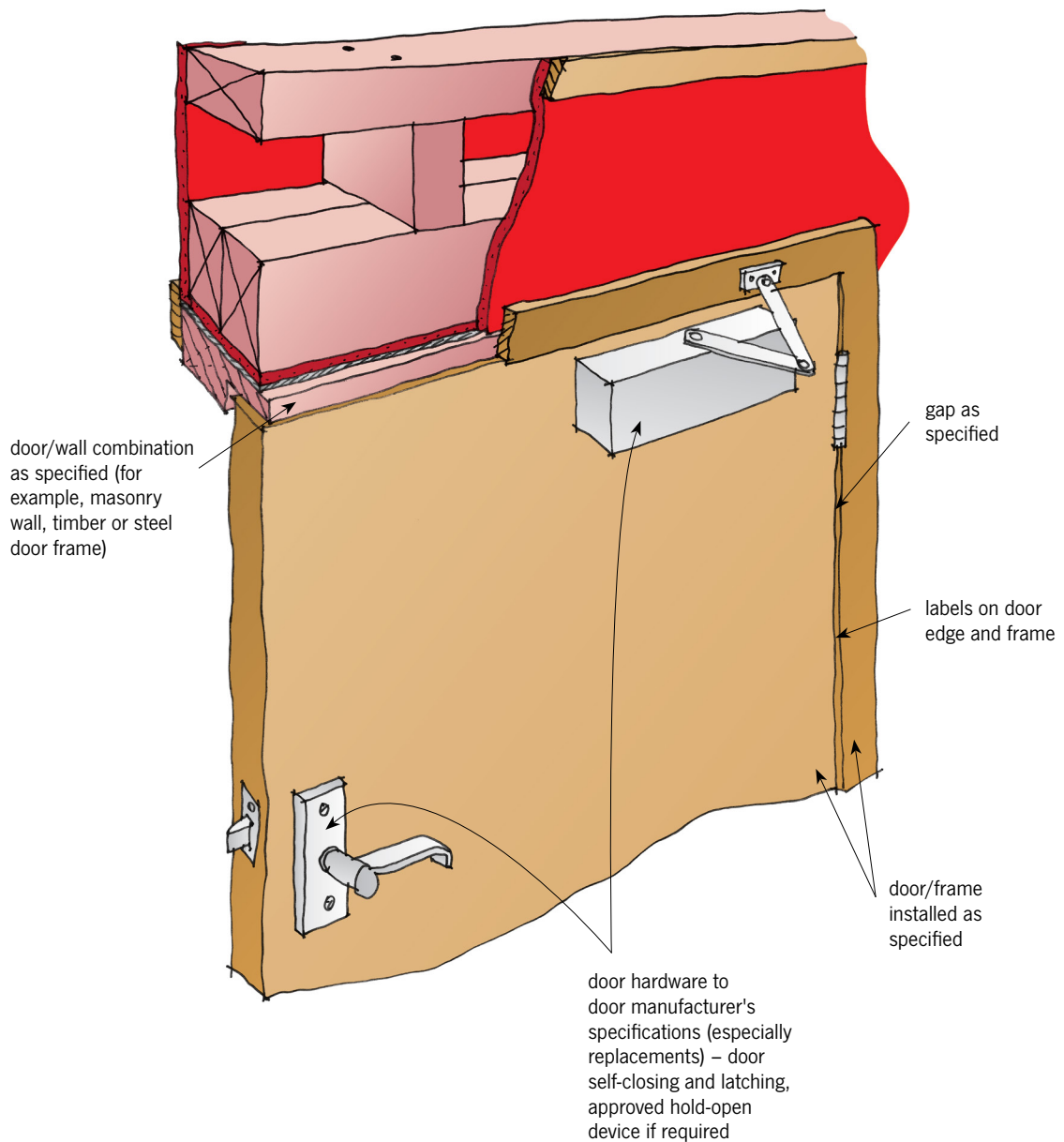

Notes

- Follow manufacturer's specifications
- Obtain data sheets, catalogues etc.
- Frame fixing as specified by manufacturer
- Gaps to edge of frame typically 3 mm
- Door stops typically 25 mm thick but may vary
- Ensure compatibility of door and wall as specified by manufacturer
- Labels required on door edge and frame

Figure 13. Typical doorset features – timber-framed wall and timber door frame

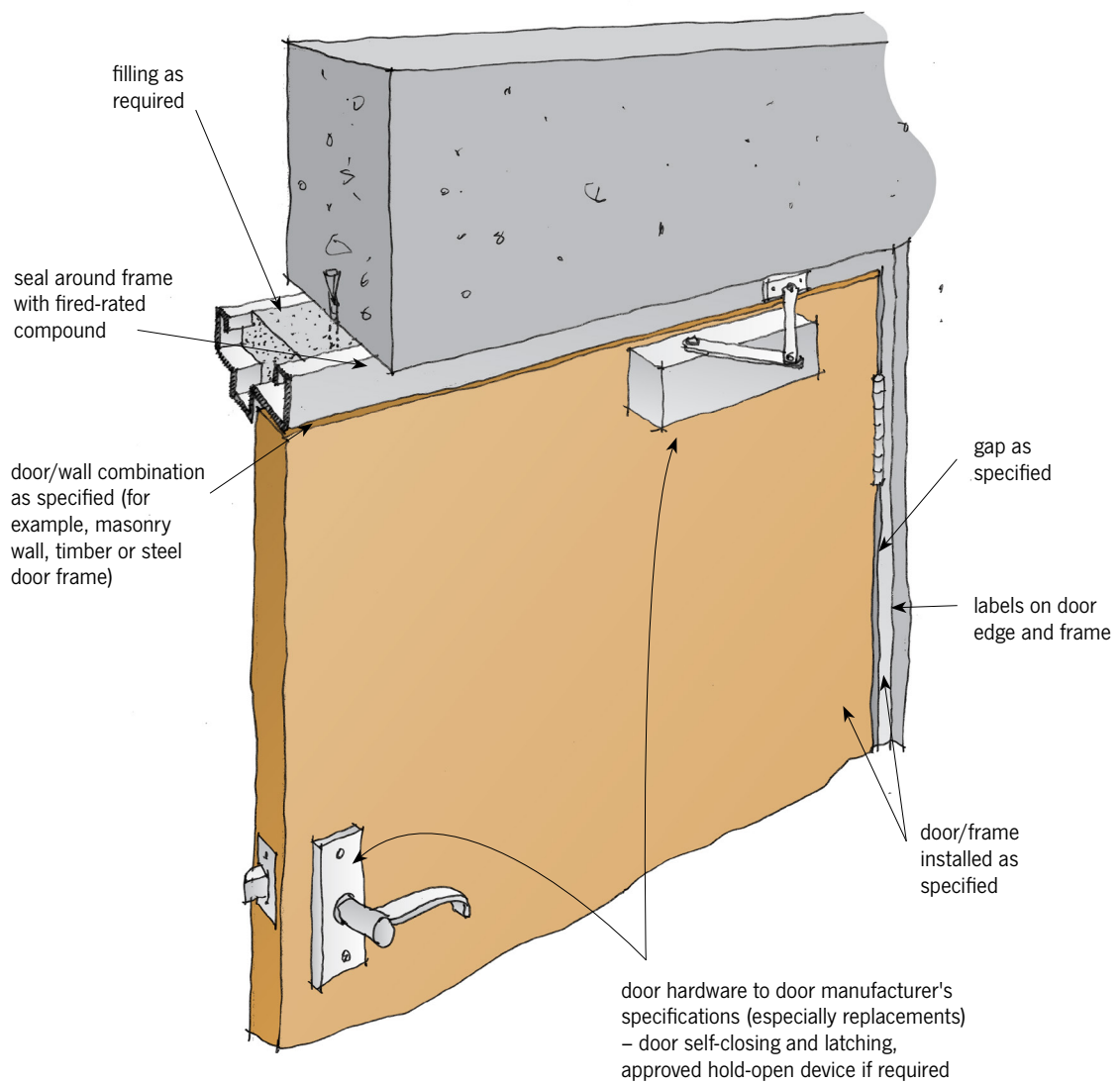

Notes

- Follow manufacturer's specifications
- Obtain data sheets, catalogues etc.
- Frame fixing as specified by manufacturer
- Hollow steel frames filled as specified by manufacturer
- Gaps to edge of frame typically 3 mm
- Ensure compatibility of door and wall as specified by manufacturer
- Labels required on door edge and frame

Figure 14. Typical doorset features – masonry wall

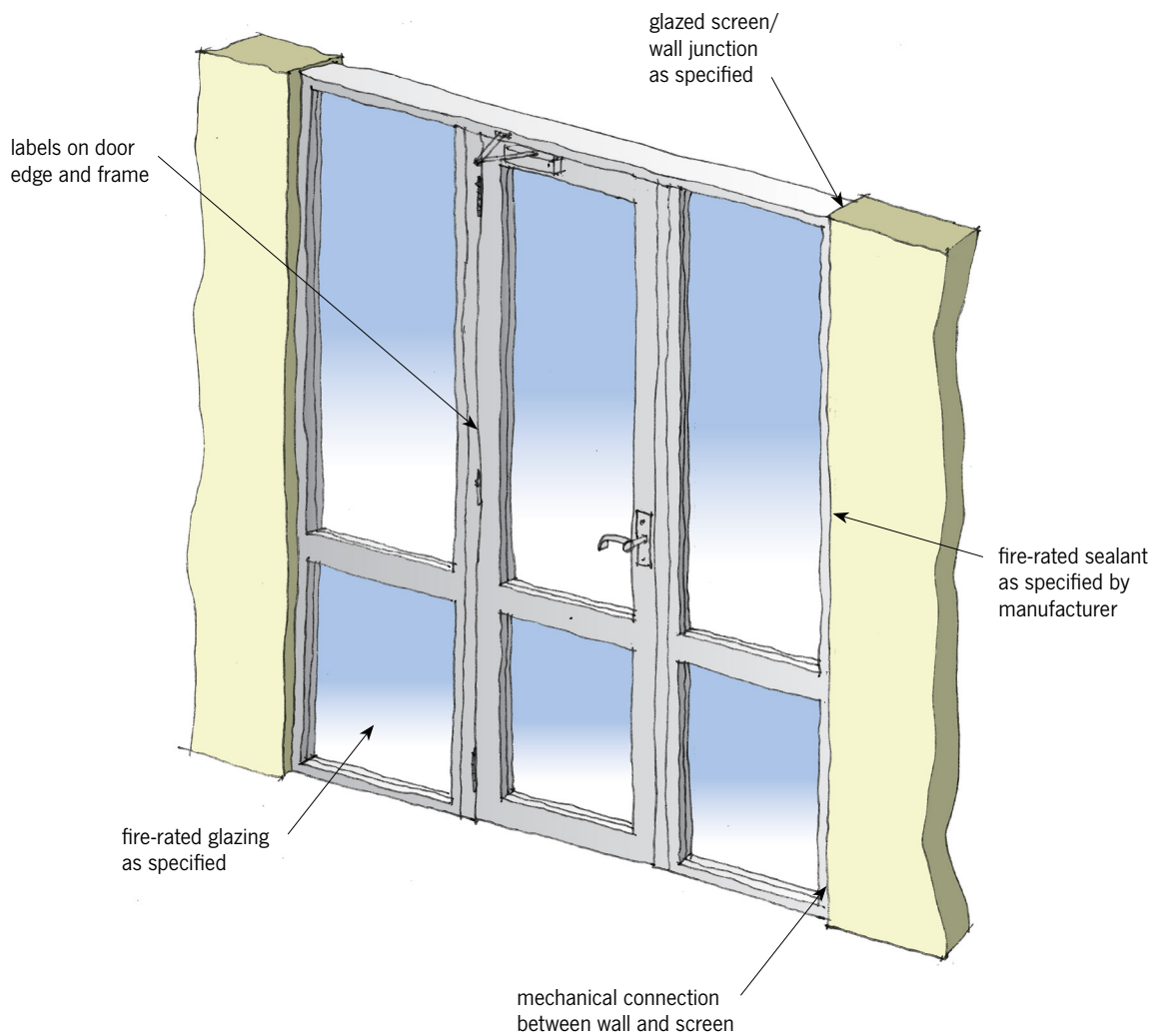

Notes

- Follow manufacturer's specifications
- Obtain data sheets, catalogues etc.
- Glazed screen fixing as specified by manufacturer
- Door as specified by manufacturer
- Ensure compatibility of glazed screen and wall as specified by manufacturer
- Ensure glazed screen is sealed to wall
- Labels required on door edge and frame

Figure 15. Typical doorset features – glazed

Doors - lifts

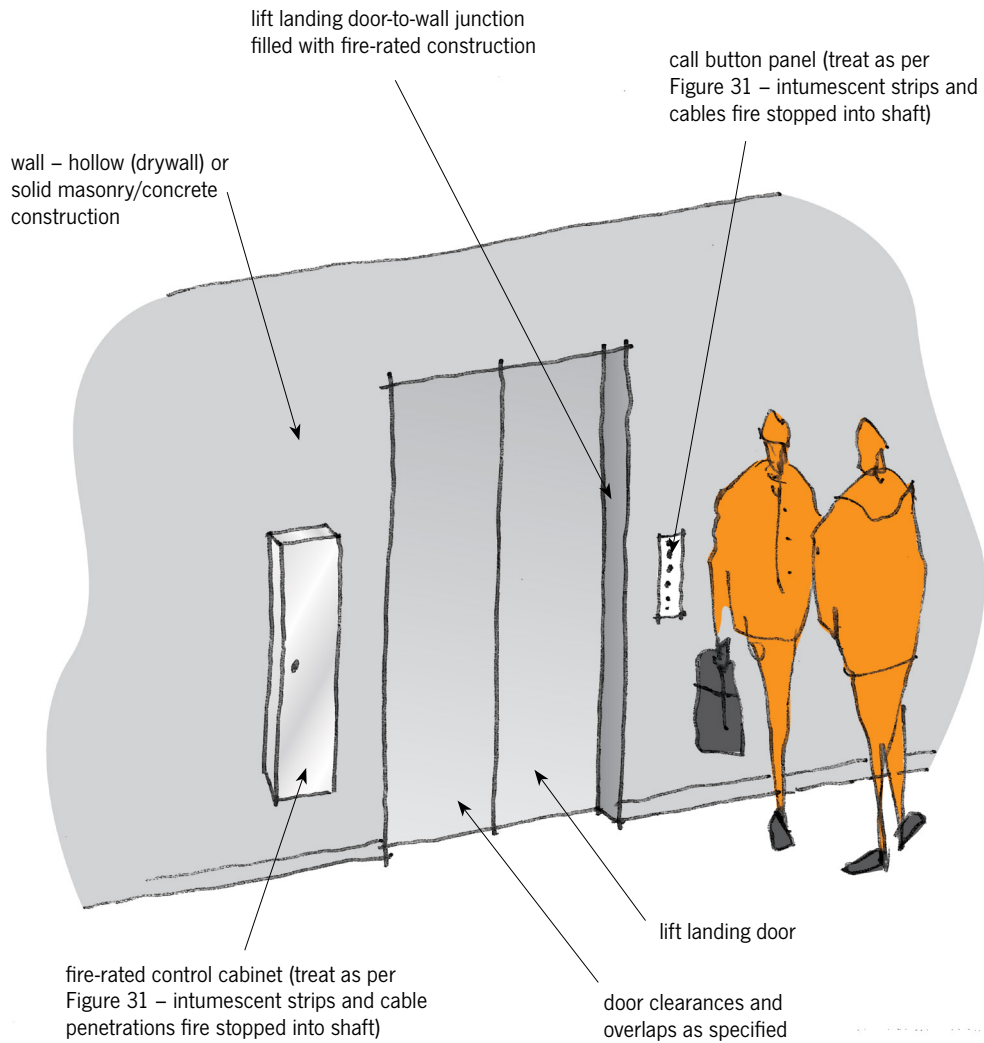

Notes

- Follow manufacturer's specifications
- Obtain data sheets, catalogues etc.
- Frame fixing as specified by manufacturer
- Older style frame fully grouted
- New frames require brackets (see Figure 17)
- Gap between frame and wall to be filled with fire-rated construction of the same FRR as wall

Figure 16. Typical lift doors – lobby

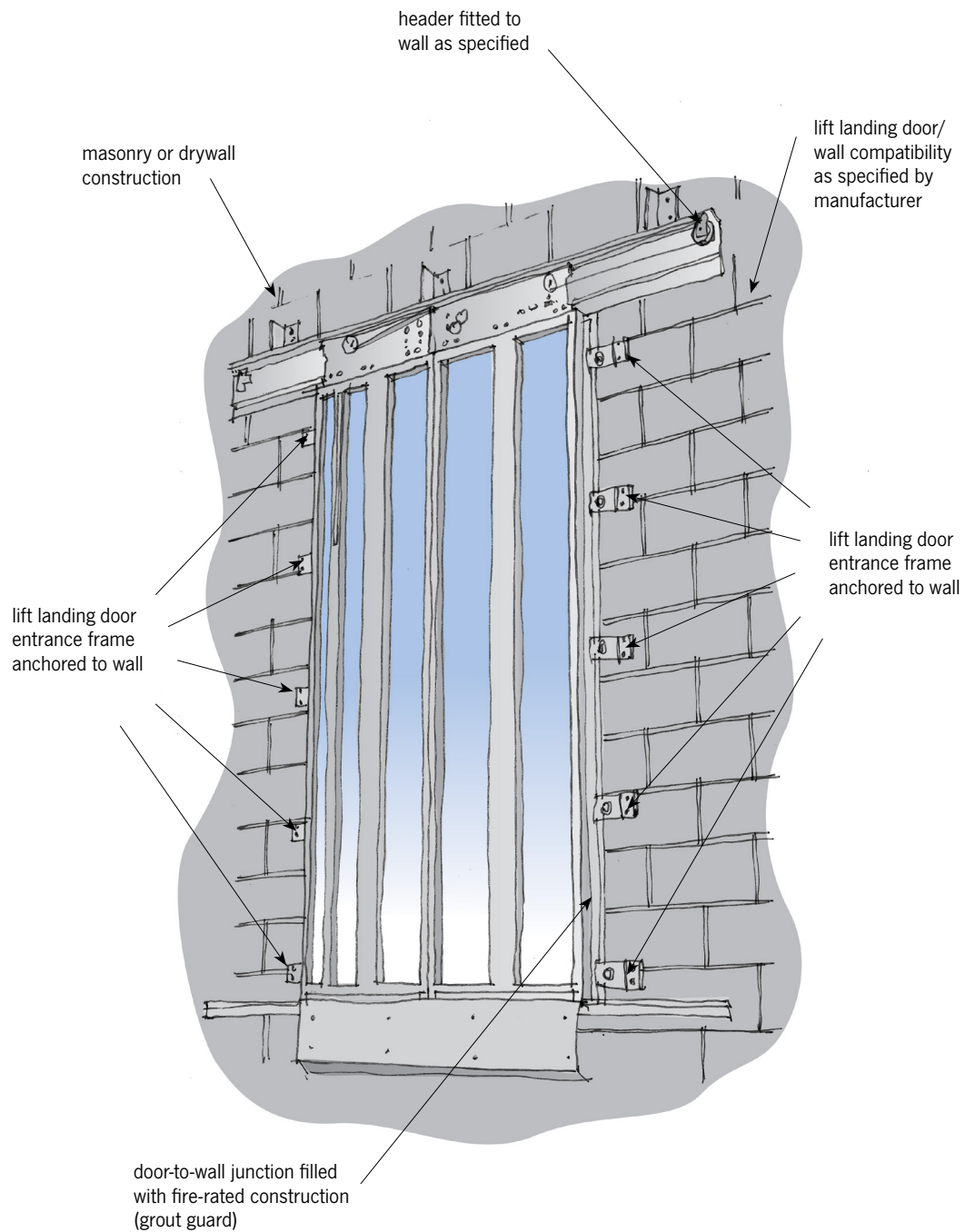

- Notes
- Follow manufacturer's specifications
 - Obtain data sheets, catalogues etc.
 - Gap between frame and wall to be filled with fire-rated construction of the same FRR as wall
 - Fire stop lift control panel (and indicator lights)
 - Number of wall fixings may vary

Figure 17. Typical lift doors – inside lift shaft

Shutters

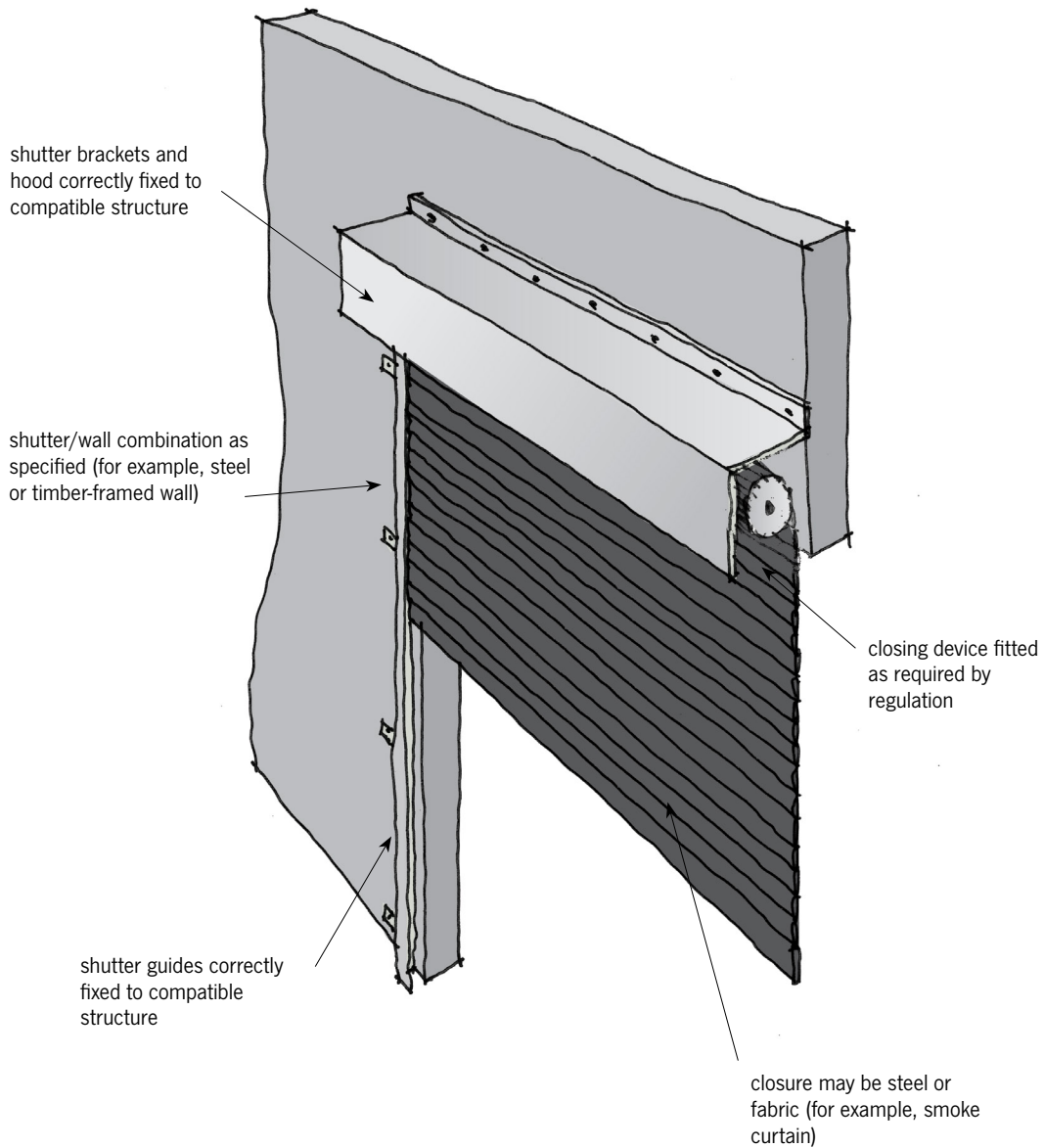

Notes

- Follow manufacturer's specifications
- Obtain data sheets, catalogues etc.
- Shutter guides attached as specified
- May require a fusible link or activation by smoke alarm
- Usually no insulation value
- Closure may be a steel curtain or fabric as in a smoke barrier

Figure 18. Typical vertical roller shutter features

Ducts

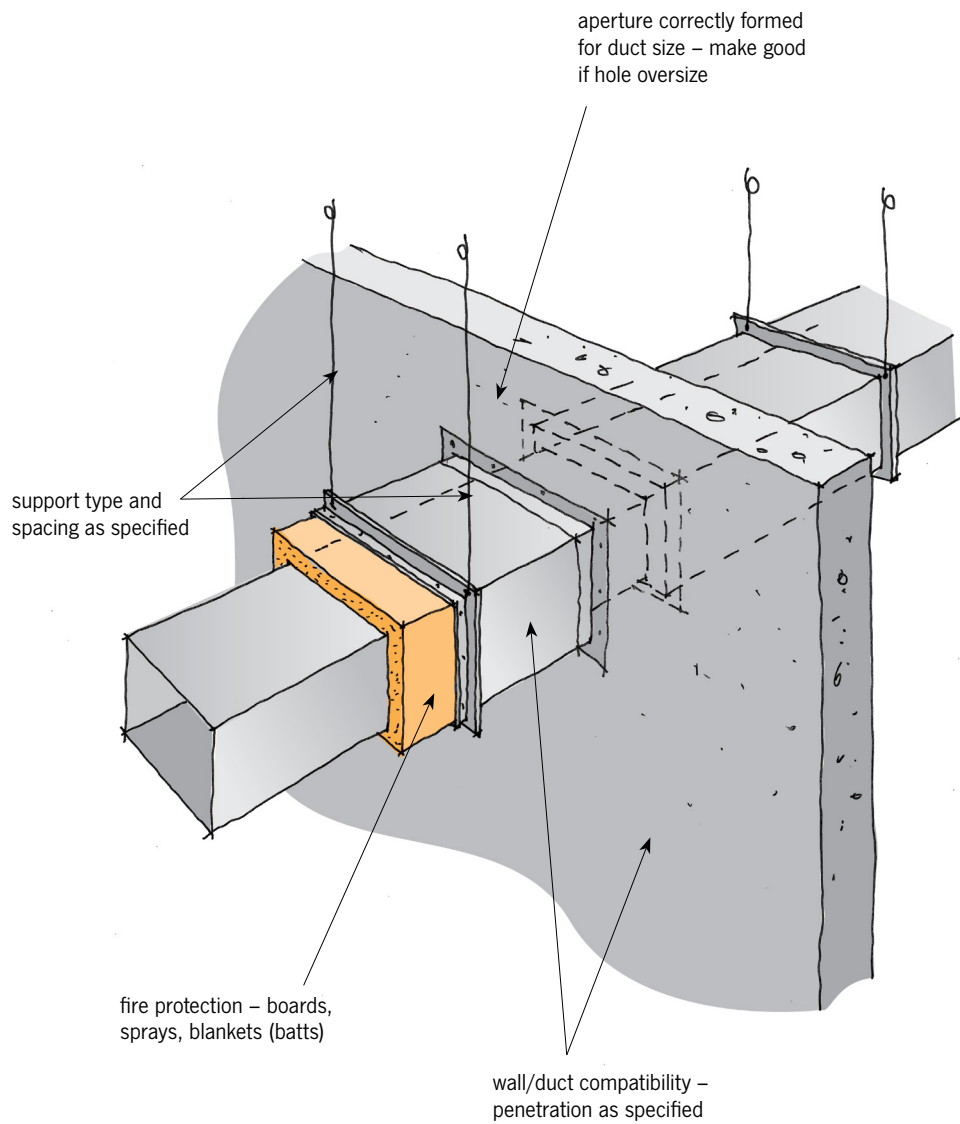

Notes

- Follow manufacturer's specifications
- Obtain data sheets, catalogues etc.
- Duct must be supported as specified by manufacturer
- Penetration to be as specified by manufacturer
- Aperture to be made good if oversize as appropriate to wall construction – for example, mortar if concrete, additional linings if drywall construction

Figure 19. Typical duct features

Fire dampers

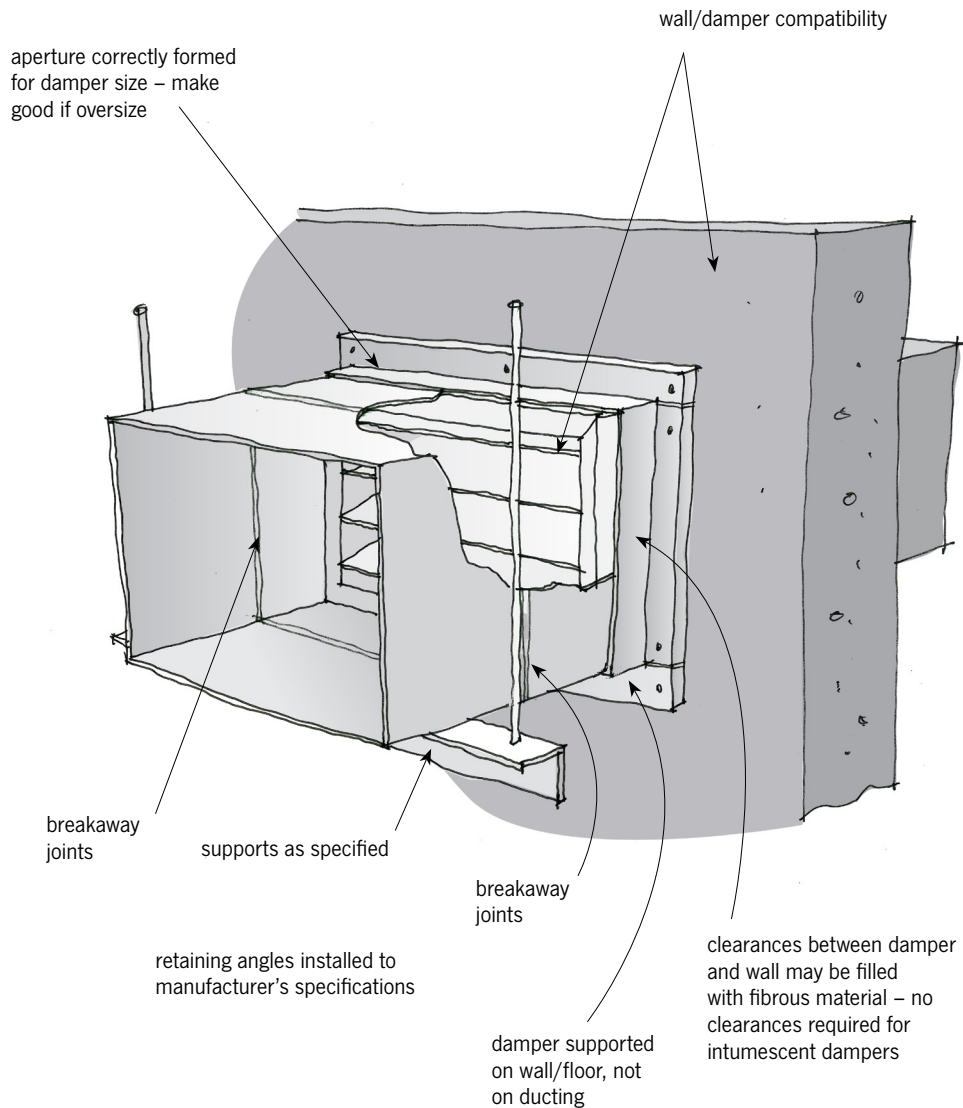

Notes

- Follow manufacturer's specifications
- Obtain data sheets, catalogues etc.
- Damper must be supported as specified by manufacturer not by duct, if any
- Penetration to be as specified by manufacturer
- Aperture to be made good if oversize as appropriate to wall construction – for example, mortar if concrete, additional linings if drywall construction
- Angles fixed only to damper and twice width of gap
- Clearances to wall as specified by manufacturer
- Gap may be filled with fire-rated material, usually mineral wool

Figure 20. Typical fire damper features – metal

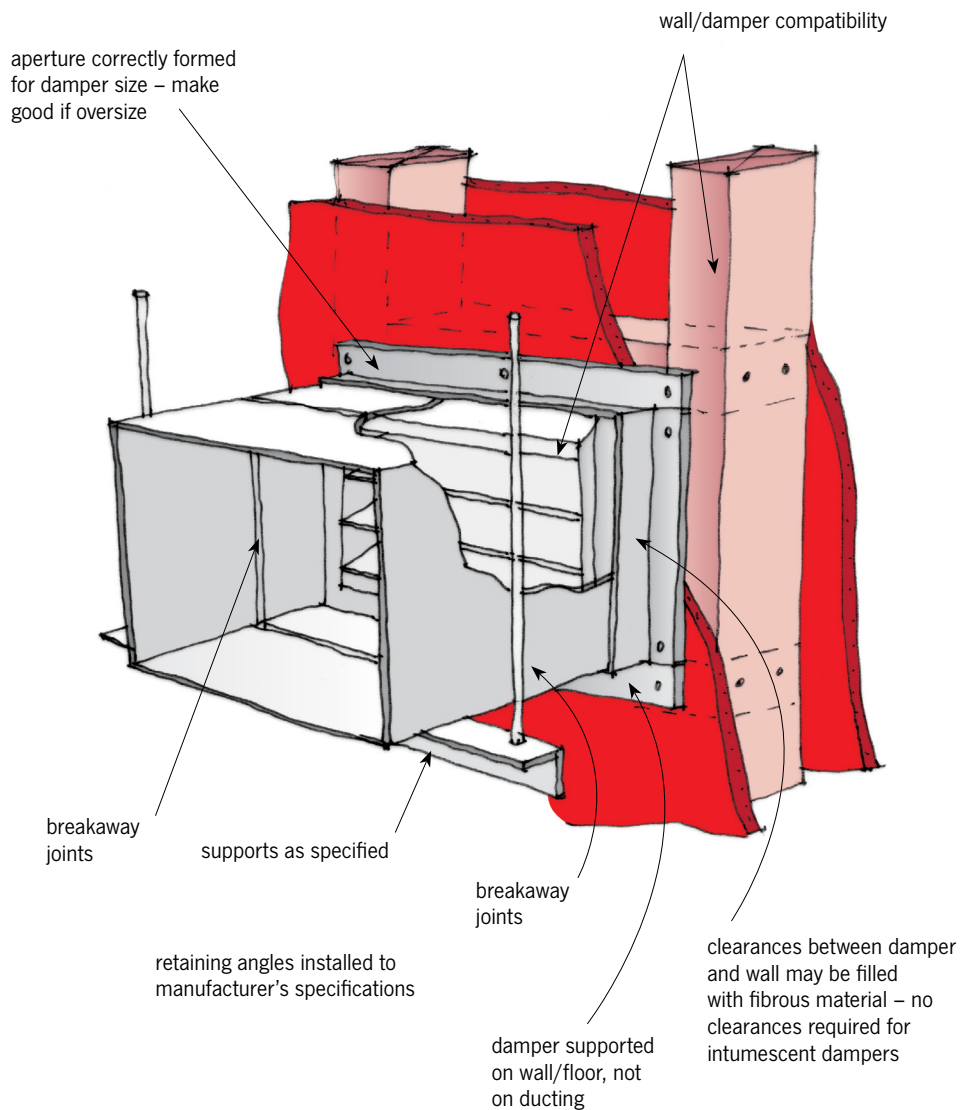

- Notes
- Follow manufacturer's specifications
 - Obtain data sheets, catalogues etc.
 - Damper must be supported as specified by manufacturer not by duct, if any
 - Penetration to be as specified by manufacturer
 - Aperture to be made good if oversize as appropriate to wall construction – for example, mortar if concrete, additional linings if drywall construction
 - Angles fixed only to damper and twice width of gap
 - Clearances to wall as specified by manufacturer
 - Gap may be filled with fire-rated material, usually mineral wool

Figure 21. Typical fire damper features – metal in framed wall

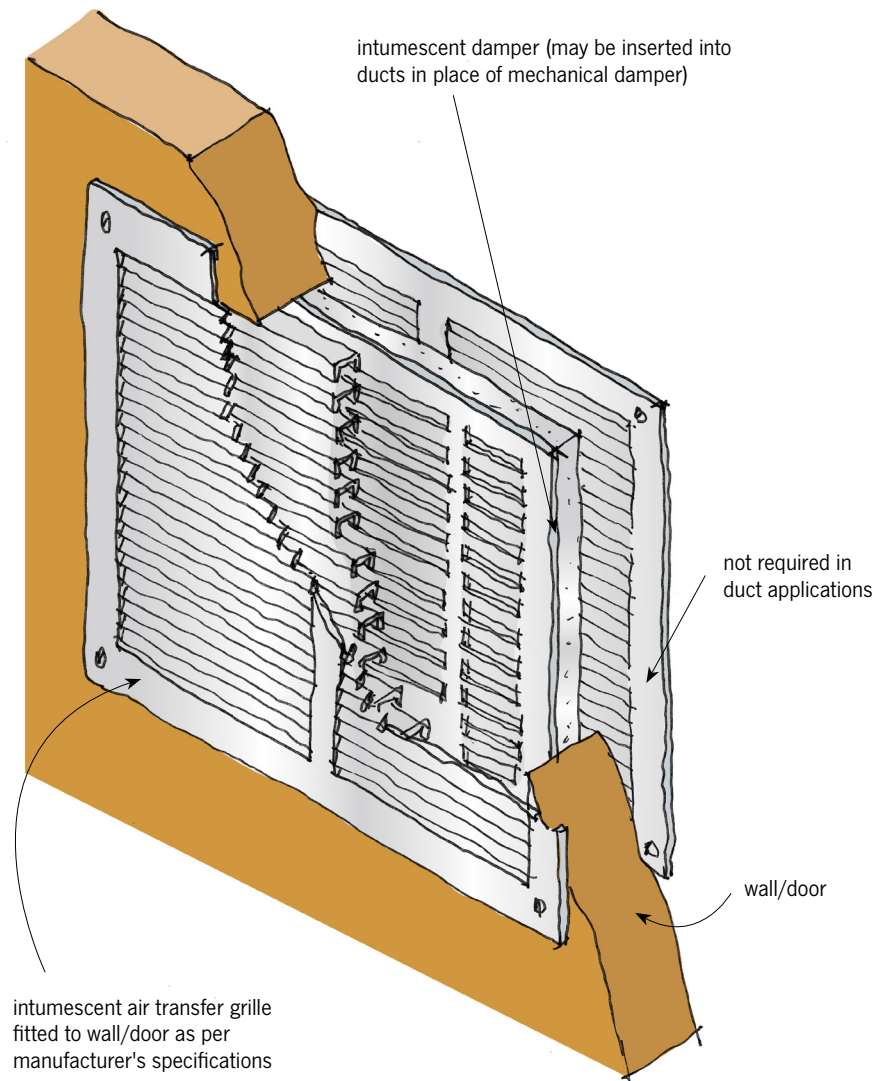

- Notes
- Follow manufacturer's specifications
 - Obtain data sheets, catalogues etc.
 - Damper must be supported as specified by manufacturer not by duct, if any
 - Check height of damper in wall or door as per manufacturer's specifications
 - Intumescent damper may be inserted into a duct section, as in Figure 20
 - Aperture to be made good if oversize as appropriate to wall construction – for example, mortar if concrete, additional linings if drywall construction

Figure 22. Typical fire damper features – intumescent

Structural fire protection

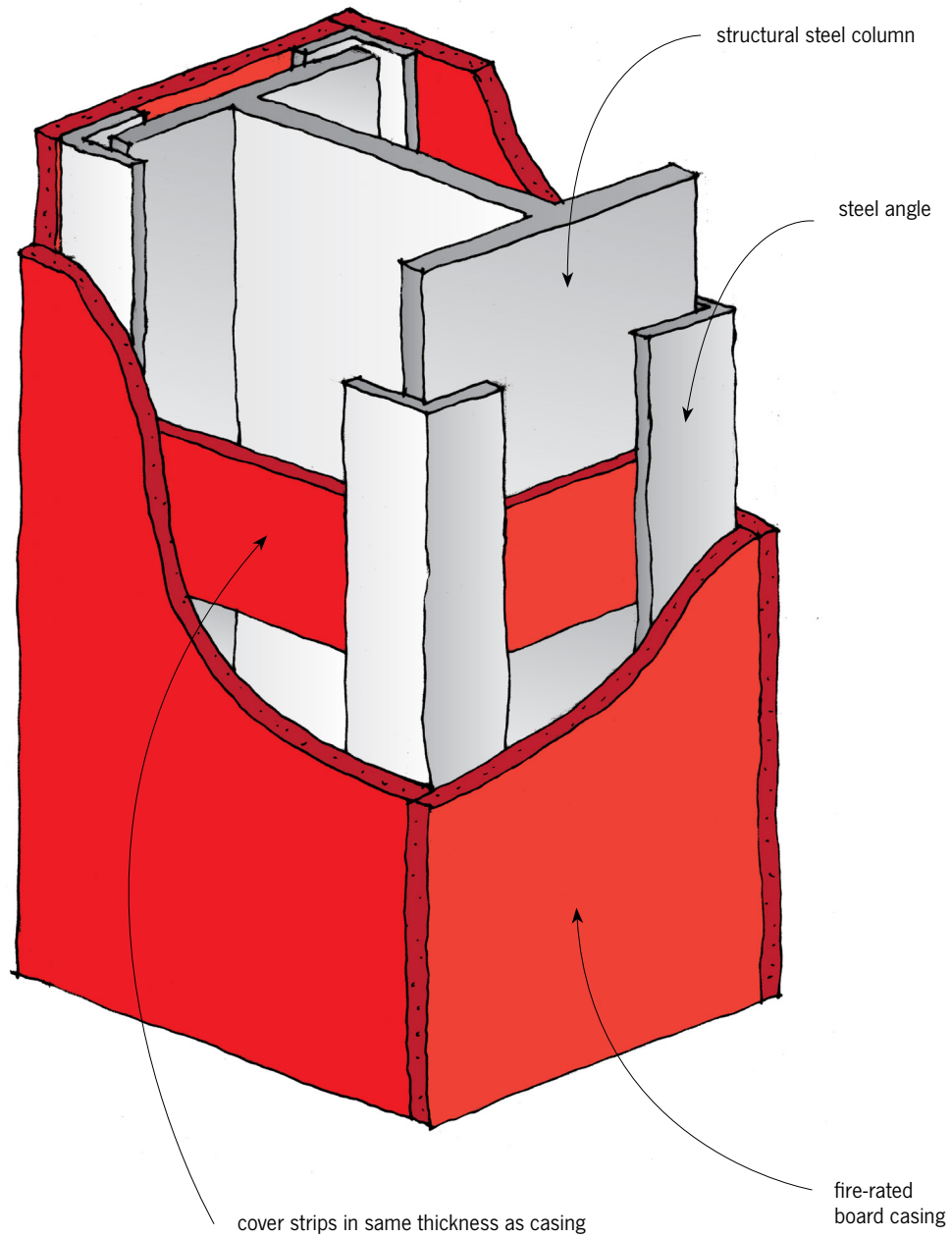

Figure 23. Structural fire protection – fire-rated boards protecting steel columns

Intumescent coatings

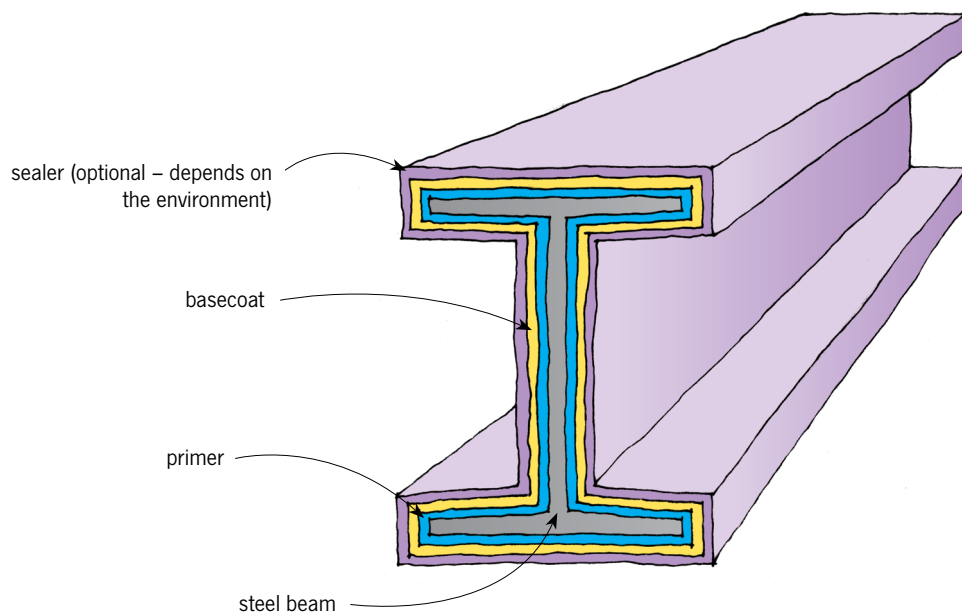
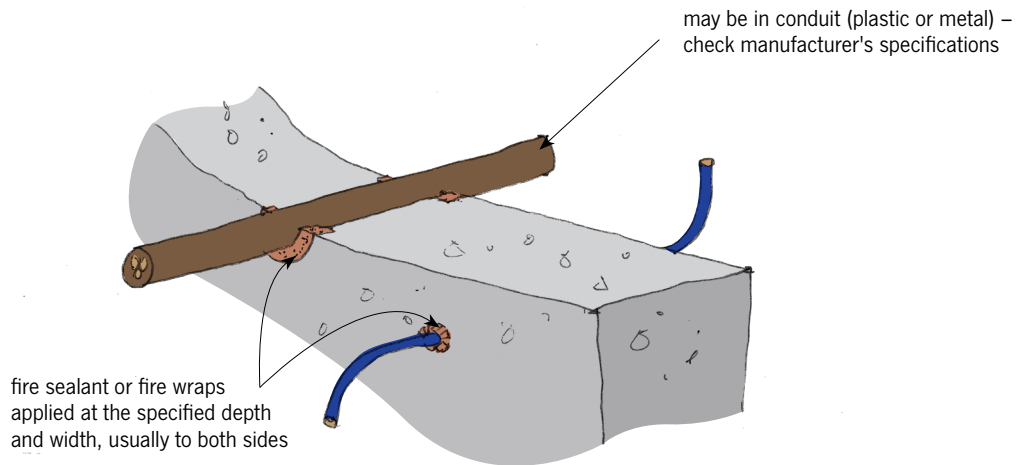

Figure 24. Intumescent coatings.

Note: Special applicators are usually required. Follow manufacturer's instructions.

(Not to scale. Thicknesses shown do not represent actual thicknesses.)

Penetration seals – electrical and information technology



a) solid construction

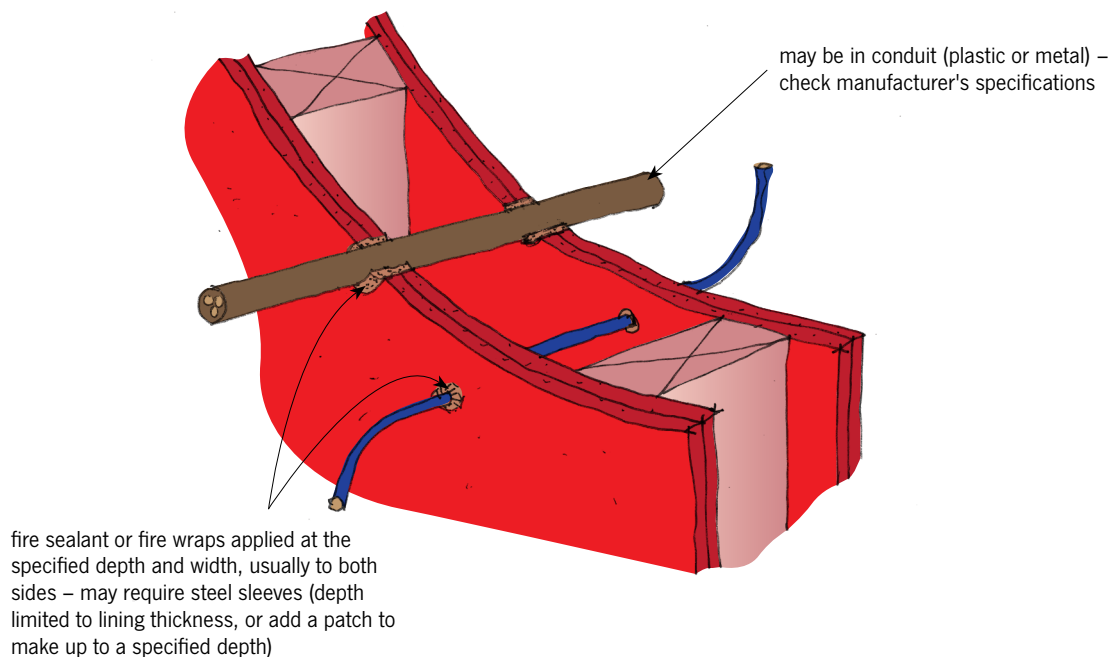

b) hollow construction – framed wall or hollow block

Notes

- Follow manufacturer's specifications
- Obtain data sheets, catalogues etc.
- For single cables, fire sealants and wraps are sufficient
- Fire sealant as specified by manufacturer
- For lined walls, if specified depth of sealant is greater than lining thickness, the lining thickness must be increased – for example, by applying a patch of additional lining
- If conduit used, it may be plastic or steel in accordance with manufacturer's specifications

Figure 25. Penetration seals – single cable

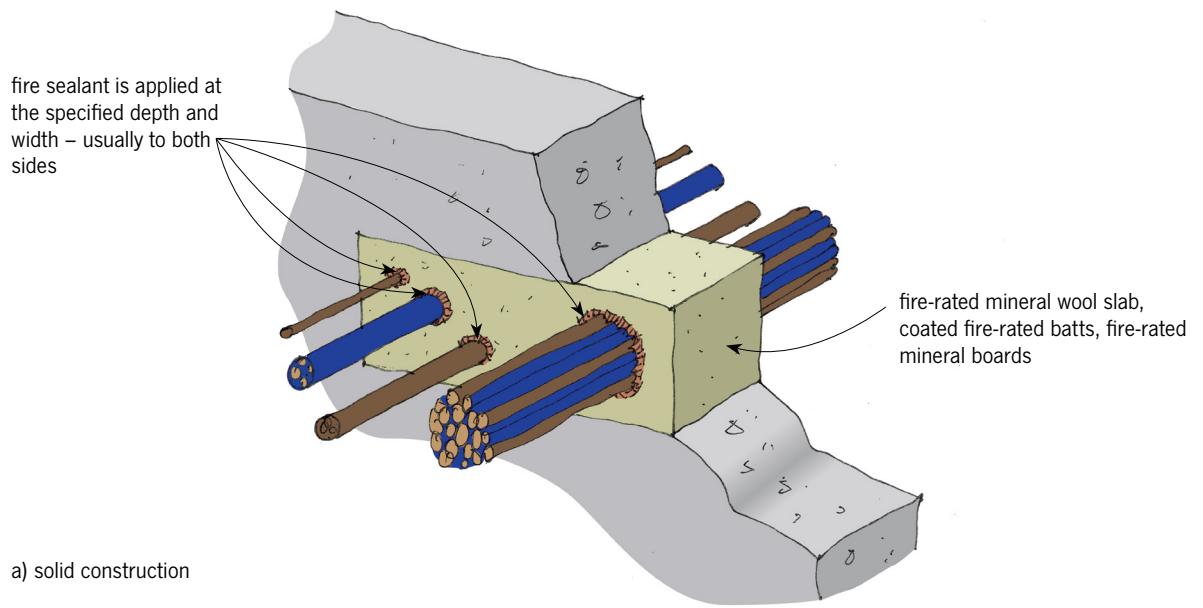

areas of wall may be alternative construction such as mineral wool panels, solid board

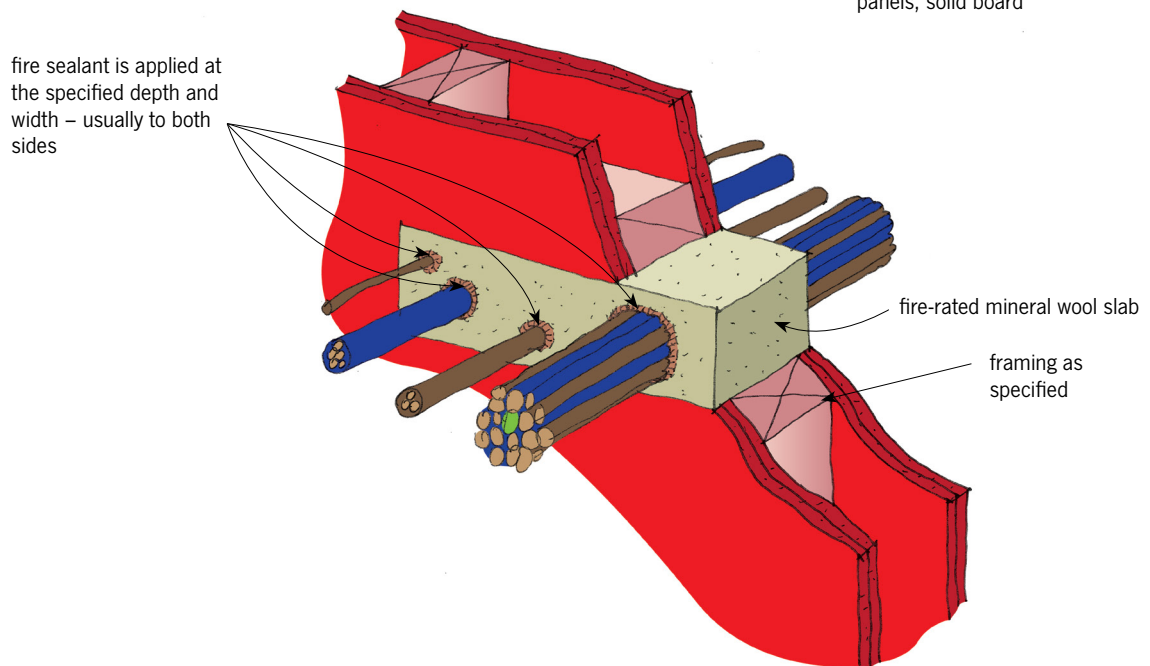

Notes

- Follow manufacturer's specifications
- Obtain data sheets, catalogues etc.
- Fire sealant as specified by manufacturer
- For lined walls, verify that the system has been rated for the lining configuration – for example, single layers or multiple layers
- Add additional patch to make up thickness if required
- Lined walls require opening to be framed with nogs (dwangs) and lined with same product as wall lining unless otherwise specified by manufacturer

Figure 26. Penetration seals – single cable – bundles

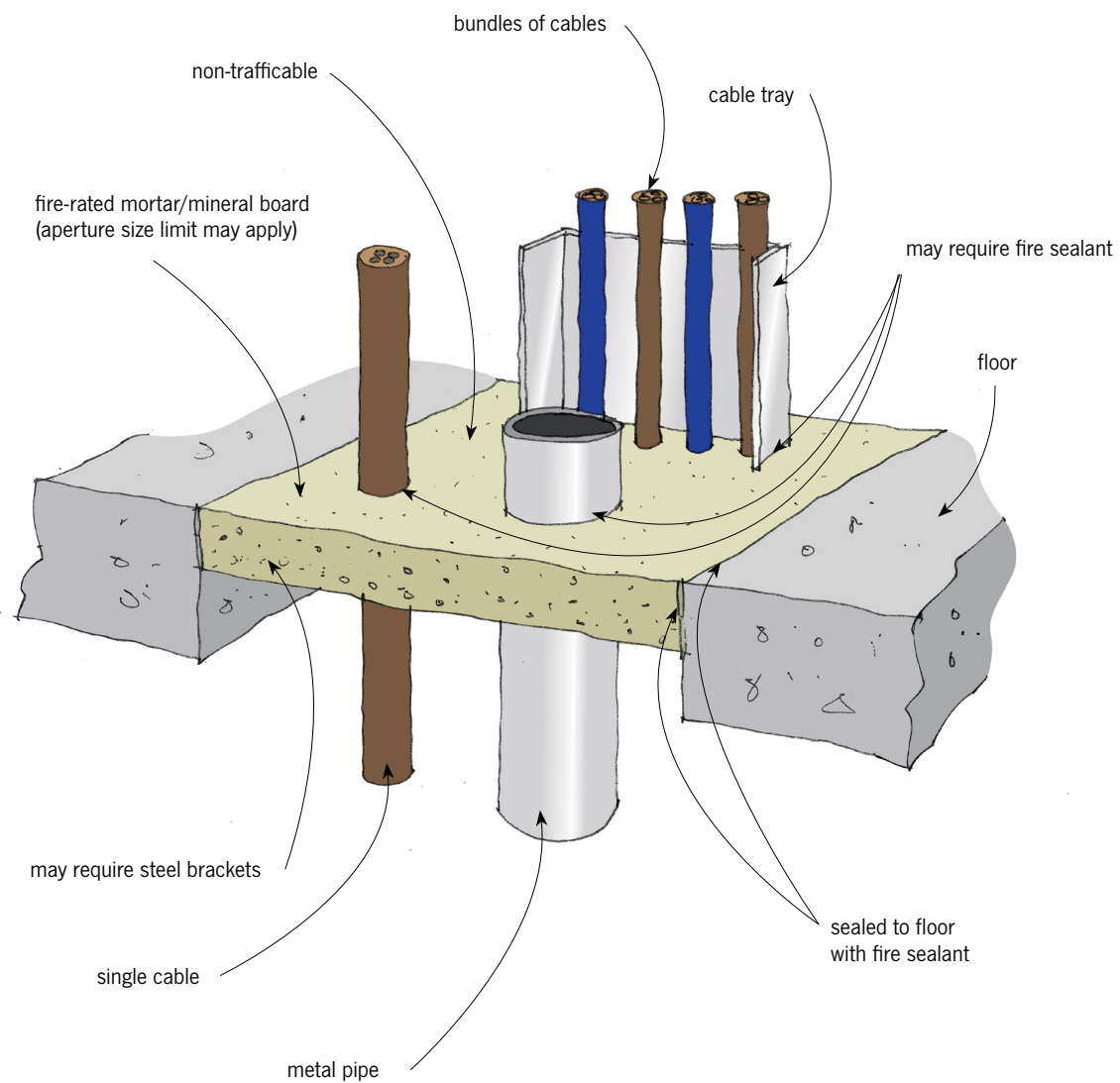

- Notes
- Follow manufacturer's specifications
 - Obtain data sheets, catalogues etc.
 - Fire sealant as specified by manufacturer
 - May require brackets around perimeter to support
 - Penetrations may require fire-rated sealant at floor junction

Figure 27. Penetrations with fire-rated infill

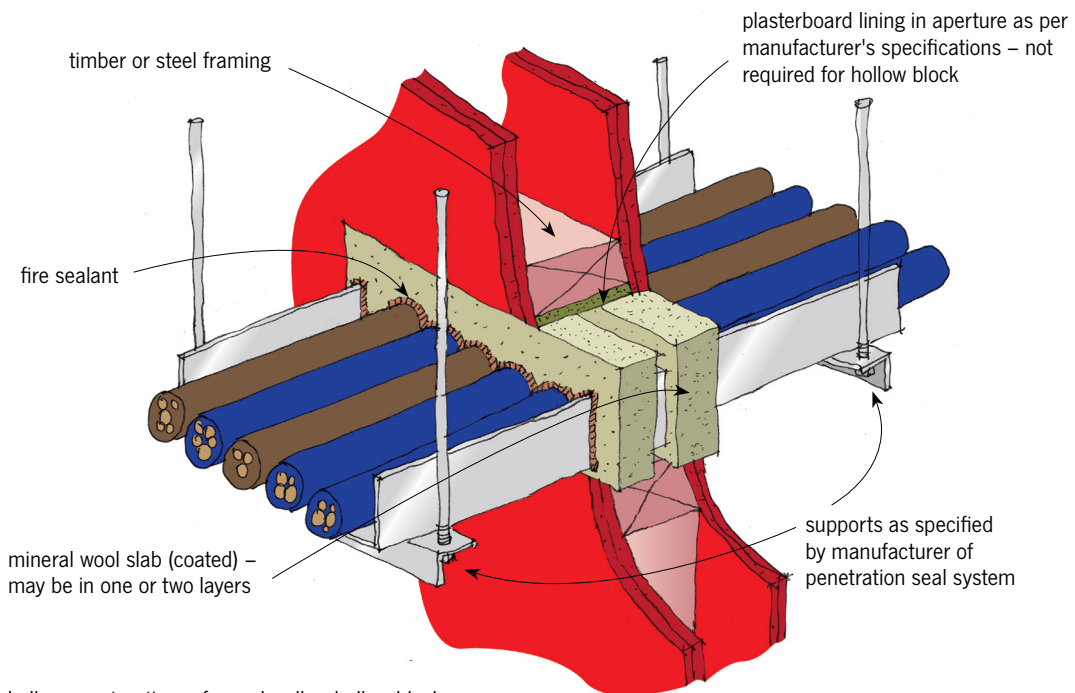
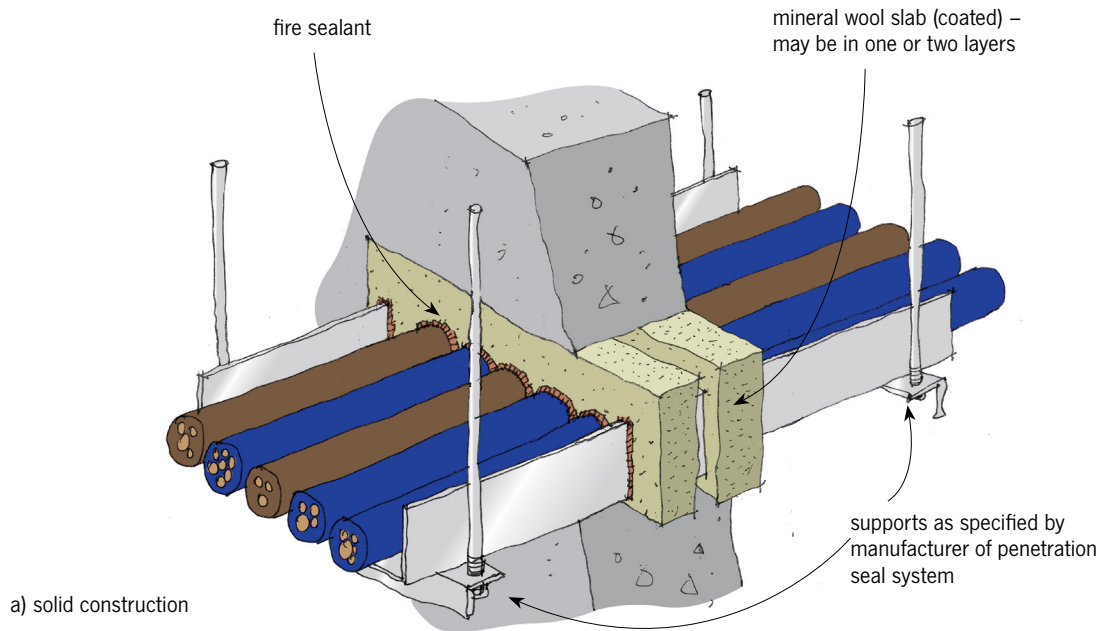

Notes

- Follow manufacturer's specifications
- Obtain data sheets, catalogues etc.
- Fire sealant as specified by manufacturer
- For lined walls, verify that the system has been rated for the lining configuration – for example, single layers or multiple layers
- Add additional patch to make up thickness if required
- Lined walls require opening to be framed with nogs (dewangs) and lined with same product as wall lining unless otherwise specified by manufacturer
- Pillows may be used instead of mineral wool slab (see Figure 30)
- Cable tray to be supported as per penetration seal manufacturer's specifications
- For hollow block, make up aperture with mortar/concrete
- Some specialist PU expanding foams may be used

Figure 28. Penetration seals – cables

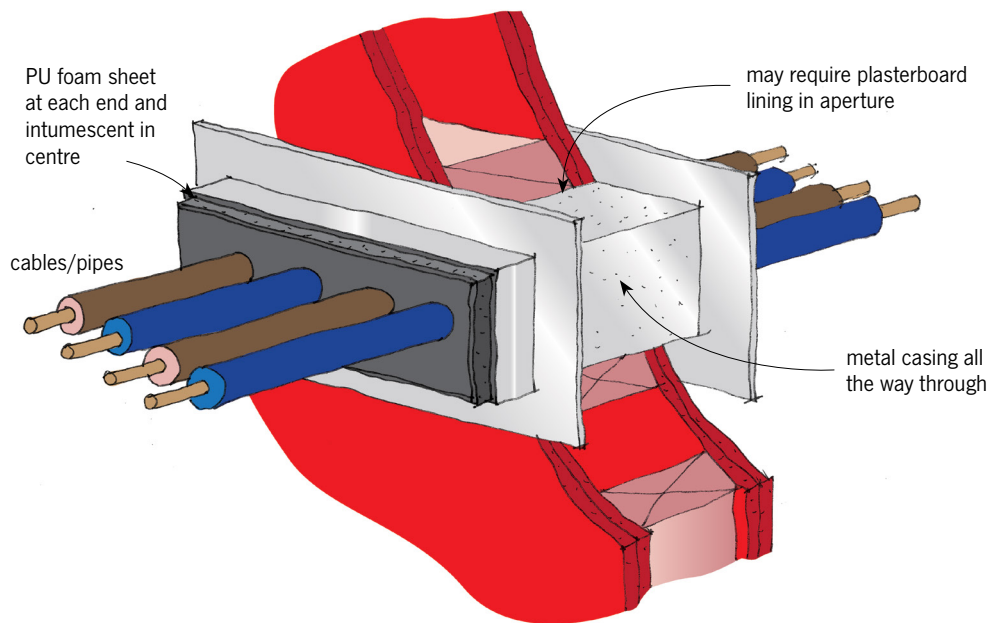
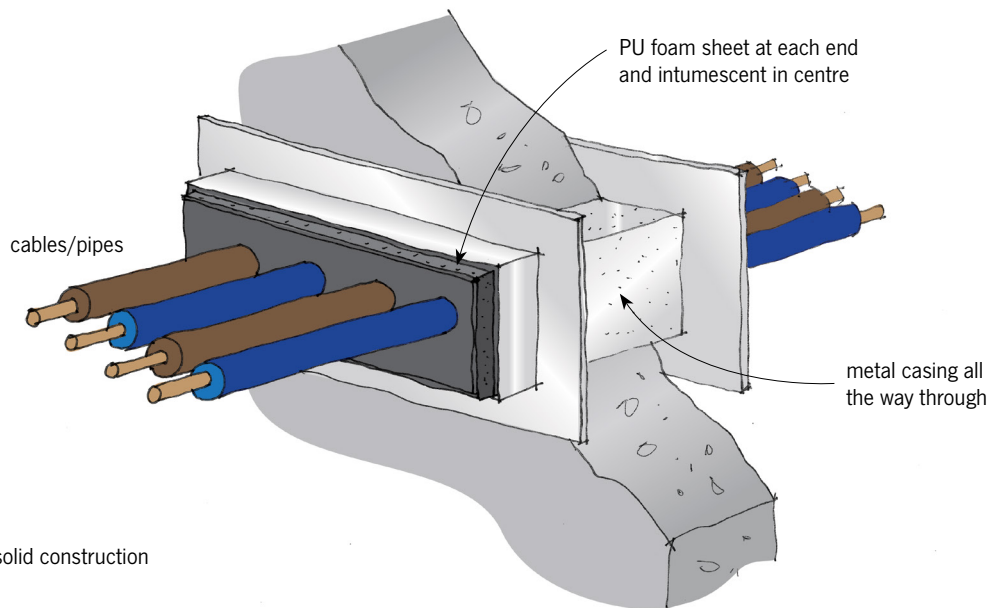

Notes

- Follow manufacturer's specifications
- Obtain data sheets, catalogues etc.
- For lined walls, verify that the system has been rated for the lining configuration – for example, single layers or multiple layers
- Add additional patch to make up thickness if required
- Lined walls require opening to be framed with nogs (dwangs) and lined with same product as wall lining unless otherwise specified by manufacturer
- For hollow block, make up aperture with mortar/concrete

Figure 29. Box penetration cable transits

may be lined wall as hollow construction as Figure 28 (b)

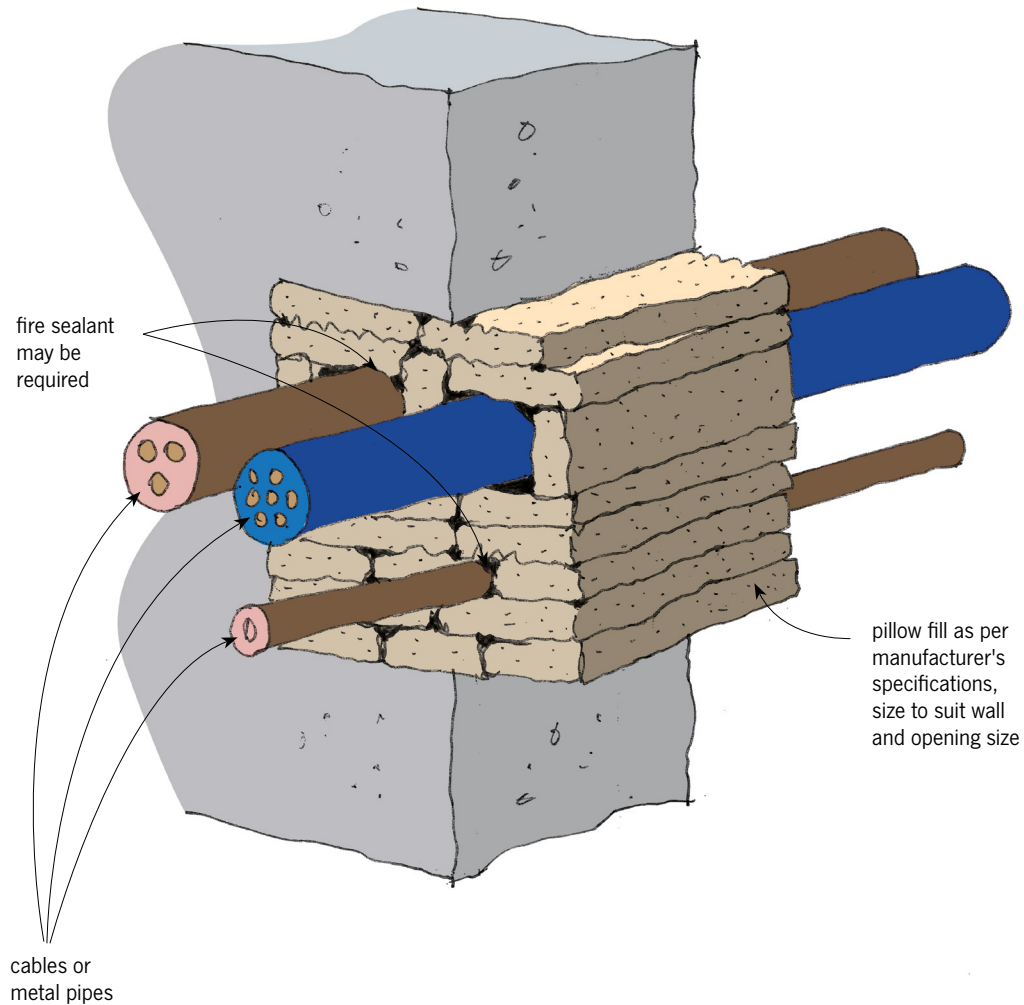

Notes

- Follow manufacturer's specifications
- Obtain data sheets, catalogues etc.
- Pillows to fill opening as per manufacturer's specifications
- Fire sealant to fill gaps around penetrations – may be cables or metal pipes
- For lined walls, verify that the system has been rated for the lining configuration – for example, single layers or multiple layers
- Add additional patch to make up thickness if required
- Lined walls require opening to be framed with nogs (dwallings) and lined with same product as wall lining unless otherwise specified by manufacturer
- For hollow block, make up aperture with mortar/concrete
- Some specialist PU expanding foams may be used

Figure 30. Pillows

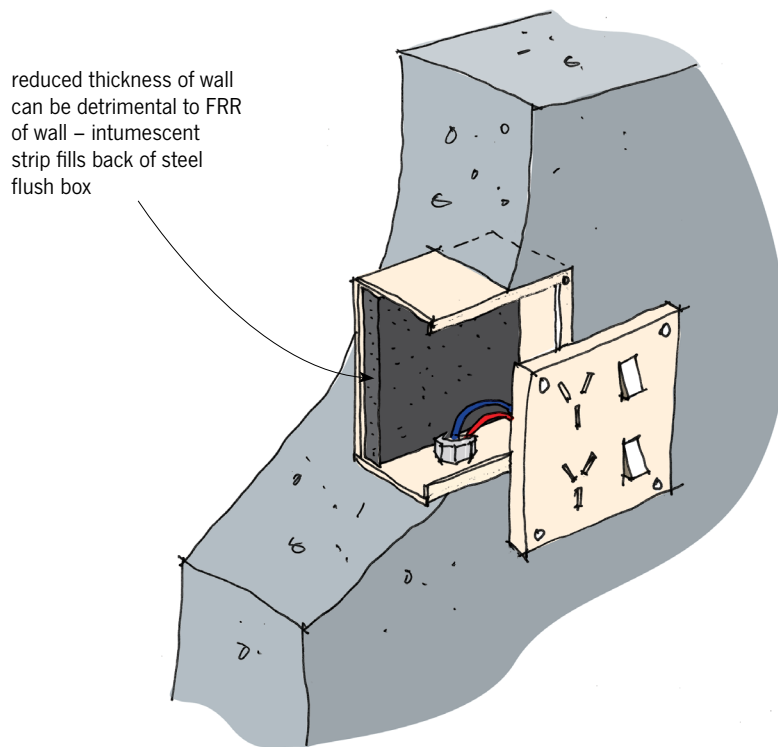

a) solid construction

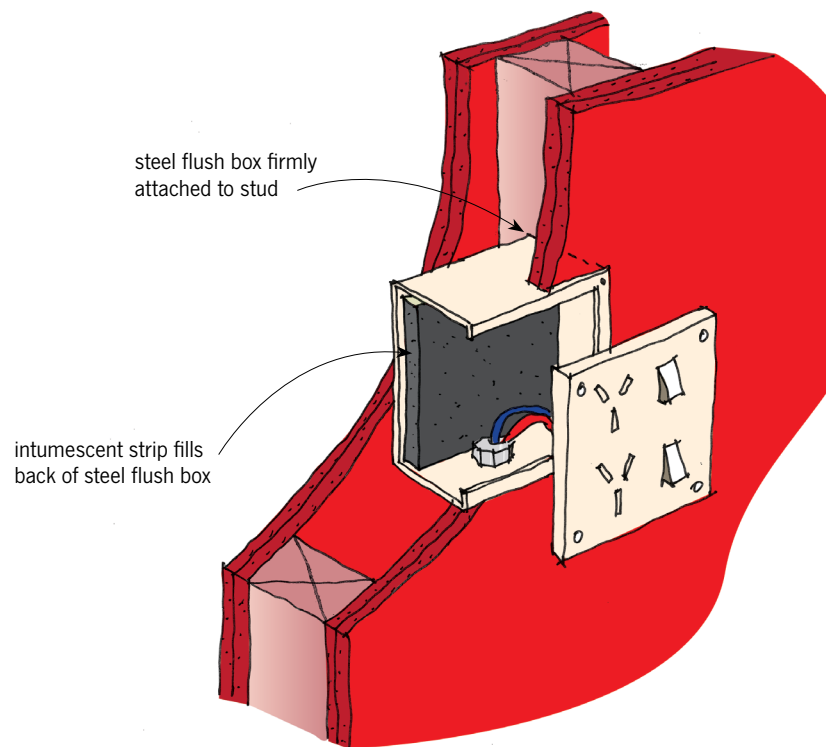

b) hollow construction – framed wall and hollow block

Notes

- Follow manufacturer's specifications
- Obtain data sheets, catalogues etc.
- For lined walls, verify that the system has been rated for the lining configuration – for example, single layers or multiple layers
- Ensure correct number of intumescent strips are pushed well back into flush box
- Only for steel flush boxes

Figure 31. Penetration seals – power outlets

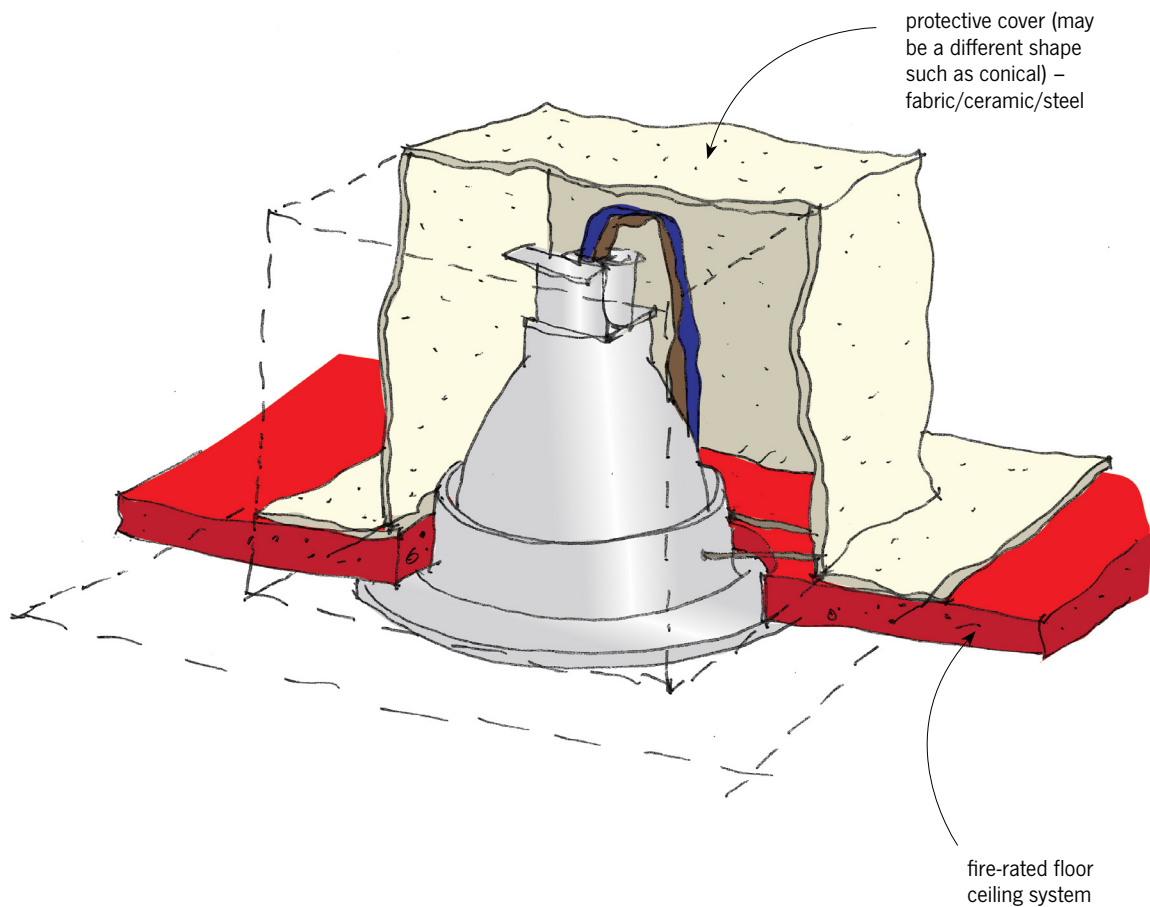

Notes

- Follow manufacturer's specifications
- Obtain data sheets, catalogues etc.
- Fire-rated floor/ceiling system
- Maintains FRR of floor/ceiling system
- Ensure light fitting is suitable for being enclosed (refer to C/ASx/Part 7 and AS/NZS 60598.2.2:2016 *Luminaires - Part 2.2: Particular requirements - Recessed luminaires*).
- Protection may be part of downlight or fitted separately in ceiling space

Figure 32. Recessed downlight cover

Penetration seals – plumbing

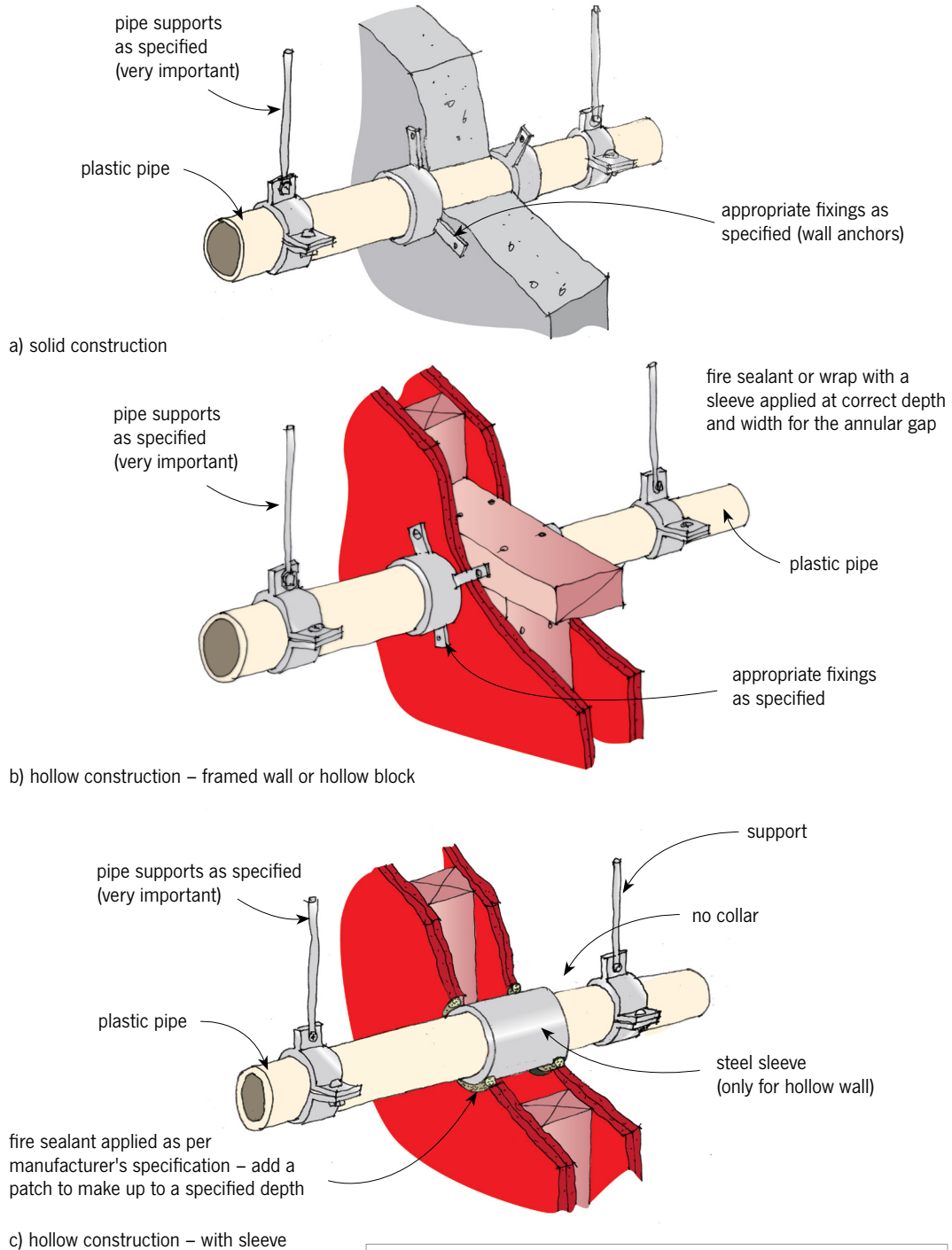

Notes

- Follow manufacturer's specifications
- Obtain data sheets, catalogues etc.
- Collars attached to each side of wall
- Fixed by tabs to wall using appropriate fixings:
 - Masonry – masonry anchors
 - Lined walls – metal expanding fixing, laminating screws
- Fixings in lined walls may be fixed directly to linings or to framing
- For lined walls, verify that the system has been rated for the lining configuration – for example, single layers or multiple layers
- Add additional patch to make up thickness if required

Figure 33. Penetration seals – plastic pipes – walls

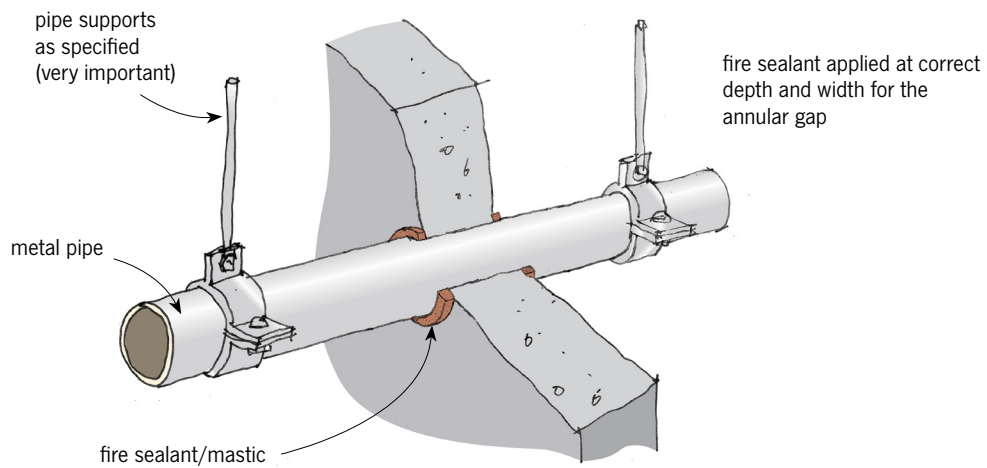

a) solid construction

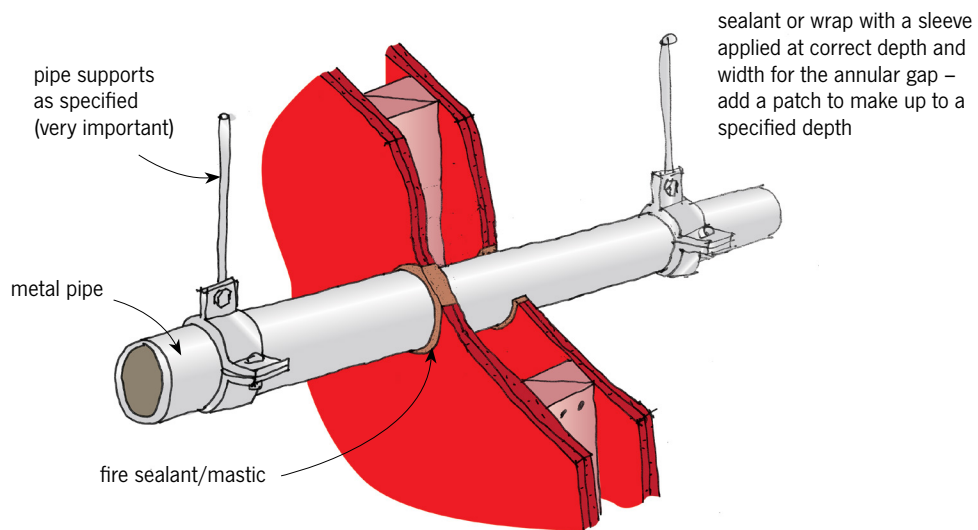

b) hollow construction – framed wall or hollow block

Notes

- Follow manufacturer's specifications
- Obtain data sheets, catalogues etc.
- Metal pipes need only fire sealant at wall junction
- Sealant is applied at correct depth in wall
- PE foam rod may be used to control depth in masonry walls
- For lined walls, verify that the system has been rated for the lining configuration – for example, single layers or multiple layers
- Add additional patch to make up thickness if required to allow application of correct depth of sealant

Figure 34. Penetration seals – metal pipes – walls

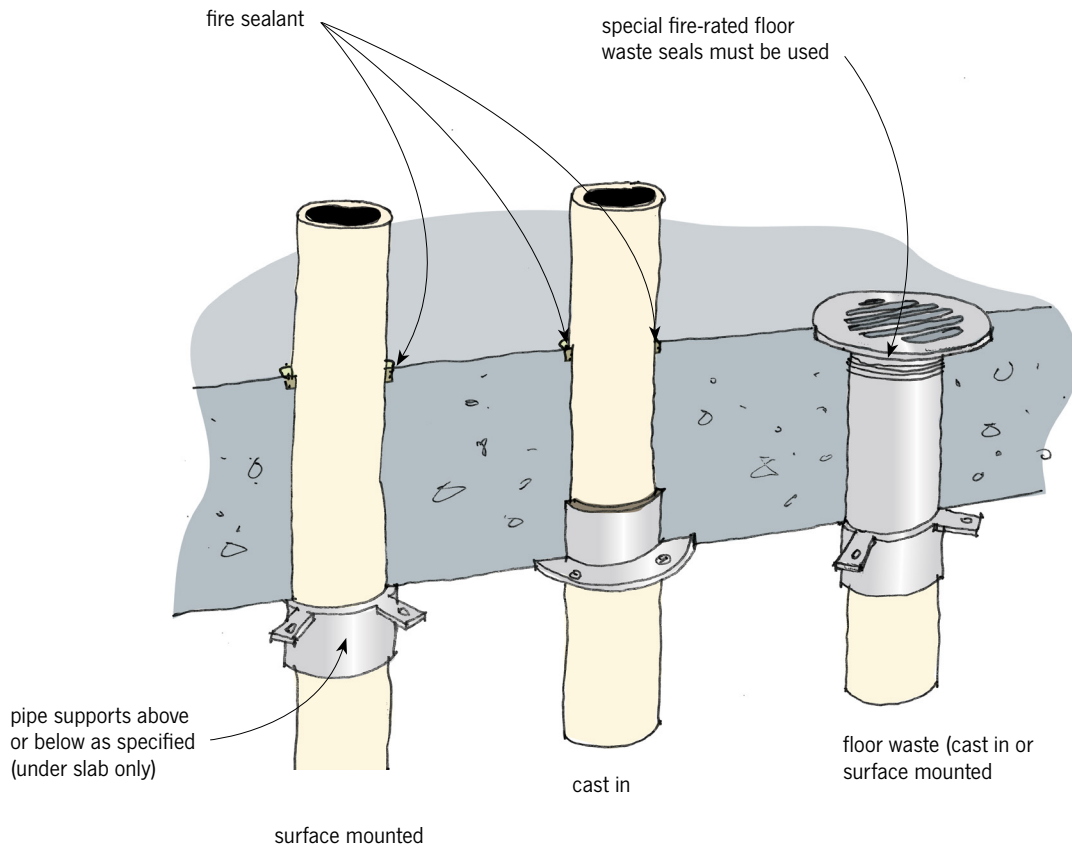

Notes

- Follow manufacturer's specifications
- Obtain data sheets, catalogues etc.
- Collars are on underside only
- Cast in, surface mounted, drop in
- Surface mounted fixed by tabs using masonry anchors or as specified by manufacturer
- Drop in fitted from top
- Metal pipes need only fire sealant or wraps
- Plastic pipes need collars
- Ensure holes are correctly sized for penetration, pipe and penetration sizes match and pipe type is appropriate for seal

Figure 35. Penetration seals – pipes – floors

Penetration seals – linear gaps

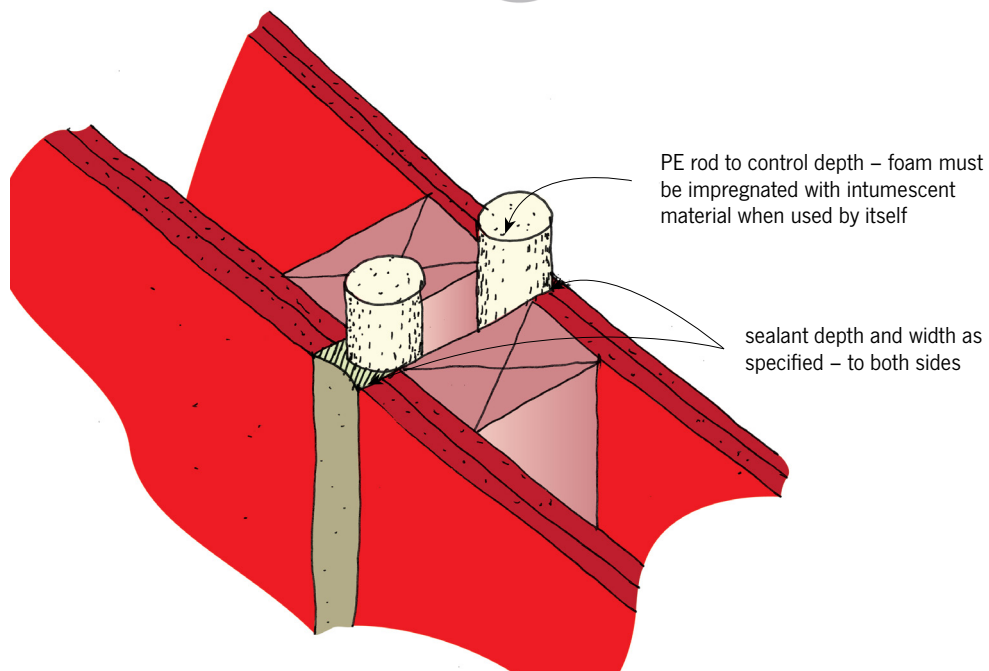
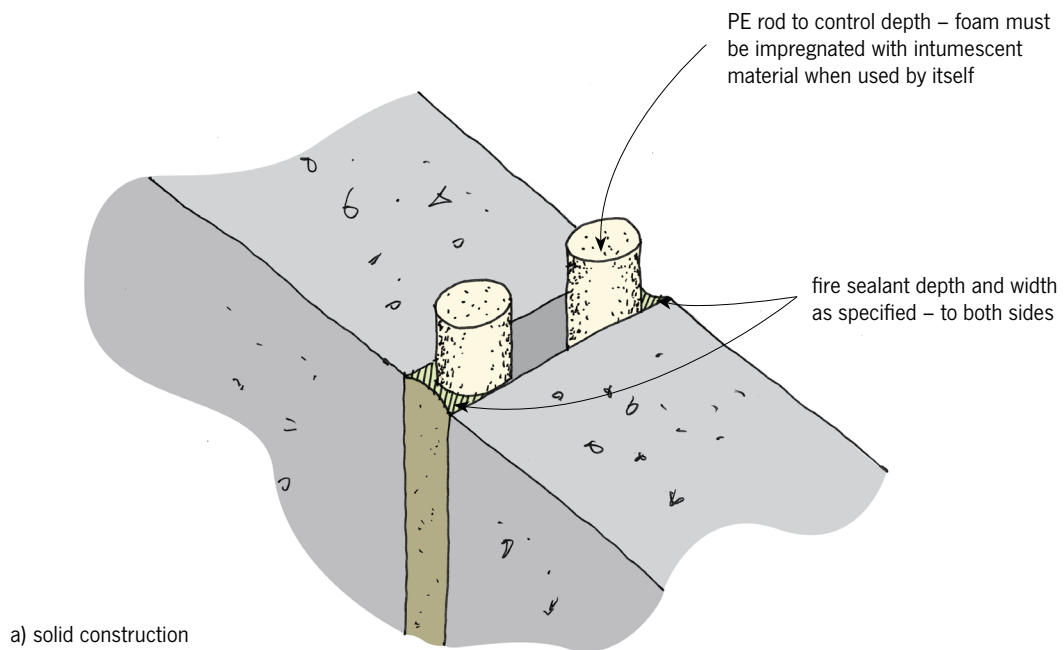

Notes

- Follow manufacturer's specifications
- Obtain data sheets, catalogues etc.
- Special application fire sealant to be used
- Note limit on width and depth of sealant
- PU expanding foam can be used

Figure 36. Penetration seals – linear gap seals – floor or wall



8

CHECKLISTS

Checklist 1: Fire and smoke barriers

This checklist covers the construction of fire-rated wall systems, including finishing work such as fire stopping and perimeter sealing.

Wall types include:

- steel or timber framed with linings of plasterboard or manufactured board, calcium silicate, vermiculite based, magnesium oxide, timber product such as MDF
- laminated self-supporting using boards (for example, cross-laminated timber construction or similar)
- masonry or concrete, hollow or solid blocks
- metal-faced composite, foamed plastic or concrete sandwich panels.

This checklist addresses specific items for the installation of fire-resistant walls:

- Obtain copies of site installation specification and consent documents.
- Obtain copies of product specification/certificates/reports or other documents such as a letter of opinion or assessment from a competent authority.
- Identify the fire rating of the wall and location in building.
- Check appropriate materials, for example, correct blocks or fire-rated boards are as consented.
- Check the installation where the wall extends between other fire-rated elements, floor, ceiling, other walls or external walls.
- Where the wall extends to the ceiling only, check the ceiling has been rated for fire.
- Are wall junctions (top, bottom and sides) as per specification?

- Are wall and lining fixings position and spacing (perimeter and in the field) and type (screws, nails) as per specification?
- Is distance of fixings from edge at joints as per specification?
- Have board joints been formed over framing or backblocked as per specification?
- Are multiple layers staggered as per specification?
- Are all boards from the same manufacturer?
- Have deflection heads (if any) been correctly installed?
- Is the wall thickness as specified (and as appropriate)?
 - Block thickness correct?
 - Number of board layers as per specification?
 - Studs (depth, thickness) as per specification?
- Has board stopping been applied as appropriate (taped and stopped)?
- Is stopping at head appropriate?
- For block walls, are mortar joints correctly bonded, particularly perpend?
- Check that penetrations, ducts, dampers and doors are correctly installed (refer appropriate checklists).
- Check that there is no damage to wall, broken chipped blocks, cracked boards - if so, seek further advice.
- Check that smoke barriers are sealed and meet the Acceptable Solution requirements.

Applicable standard: AS 1530.4-2005.

Checklist 2: Fire-resistant doorsets

Doors - hinged and pivoted

Door types include:

- solid timber
- cored doors with MDF or plywood facings with cores of:
 - timber product boards, MDF, particleboard, proprietary combustible material
 - mineral compounds
- timber framed
- steel framed filled with cement grout, plasterboard, mineral wool or solid manufactured boards.

This checklist addresses specific items for the installation of hinged or pivoted fire doors:

- Obtain copies of site installation specification and consent documents.
- Obtain copies of product specifications.
- Is the installed door approved for the relevant type of wall (masonry, plasterboard etc.)?
- Are door openings (apertures) prepared to the job specification or requirements of the manufacturer?
- Is the door frame installed correctly with fixings as per specification?
- Is the door frame to wall junction backfilled and covered (architrave) as per specification?
- Does hardware (closers, locks, selectors, kick-plates etc.) comply with specifications and approval?
- Check hinges are aligned and door is not binding.
- Check door gaps are within specified limits (not greater than 3 mm or as specified by the manufacturer).
- Check door closes and latches (if provided) under the action of the door closer.
- Check sill complies with specification and sill gap is not excessive - a maximum sill clearance of 10 mm for a non-combustible floor or 25 mm for a combustible floor covering (unless otherwise specified).
- If the door is also a smoke control door required to meet C/AS1-7, the maximum average gaps (excluding pre-easing) are leaf to frame 3 mm, leaf to leaf 5 mm, leaf to top of any floor covering 10 mm.
- Check door performance label is attached to door edge and door frame with all required information (to be installed by the manufacturer or certifier).
- Check any applied surface finish does not exceed 0.5 mm in thickness and is not nitro-cellulose based.
- Check door seals, if any, are approved type and installed as per specification.
- Check vision panels are fire rated and insulating or not greater than 0.65 m² (for example, 200 x 325 mm or 255 x 255 mm).
- Check vision panels are sound and firmly installed and are fitted with full perimeter glazing tape and glazing beads.
- Check any mastic is approved type according to the specification.
- Check any applied coating (paint) does not exceed 2 mm thickness unless included in any certification.
- Check door performance label is attached to door leaf and frame and is minimum 50 x 25 mm.

- Door frame performance label contains:
 - name of the certifier
 - name of the manufacturer
 - FRR of the doorset in minutes.
- Door leaf performance label contains:
 - number of the standard (NZS 4520:2010 from October 2010, otherwise AS/NZS 1905.1:1997 *Components for the protection of openings in fire-resistant walls - Fire-resistant doorsets*)
 - FRR in minutes
 - name of the manufacturer/sponsor
 - doorset number
 - year of manufacture.

Applicable standards: NZS 4520:2010, AS/NZS 1905.1:1997, AS 1530.4-2005.

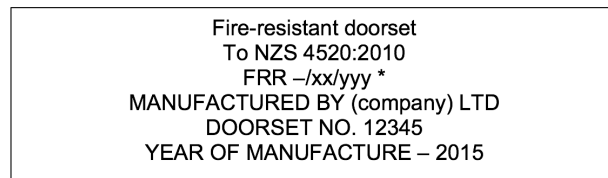

Above is an example of label information for a fire-resistant doorset.

*Though not required by NZS 4520:2010, SM may be added to indicate that it is a smoke control door.

Doors - sliding

This checklist addresses specific items for the installation of sliding fire doors:

- Obtain copies of site installation specification and consent documents.
- Obtain copies of product specification.
- Is the installed door approved for the relevant type of wall (masonry, plasterboard etc.)?
- Check door openings (apertures) are prepared to job specification or requirements of manufacturer.
- Check door track is installed correctly with fixings as specification.
- Check hardware (closers, hinges, locks, selectors, kick-plates etc.) complies with certification.
- Check doors are not binding.
- Check door clearances and overlaps:
 - When closed, the door leaf overlaps the clear opening by not less than 75 mm at each jamb and at the door head.
 - Average clearance between the face of the door leaf and the return of the frame or wall face within the area of required overlap at the top and sides of not more than 10 mm.
 - Maximum clearance at any point of 15 mm.
 - Sill clearance of 10 mm for a non-combustible floor or 25 mm for a combustible floor covering.
- Check restraint brackets (flame guards) and/or interlocking steel sections are installed as shown in approved specifications, are fixed adequately and are functional.

- Check fusible links, where fitted, are intact, unpainted and in a suitable location within the air stream.
- Check electromagnetic hold-open devices or release devices operate satisfactorily and door closes when power is off.
- Check pulley cables are free of fraying or kinks.
- Check pulleys rotate freely.
- Check counterweight guard (if any) is located with the bottom 150 mm from the sill.
- Check frame (if any) is correctly installed.
- Check any surface finish does not exceed 0.5 mm in thickness and is not nitro-cellulose based.
- Check door seals, if any, are installed in accordance with the specification.
- Check vision panels are fire rated and insulating or not greater than 0.65 m² (for example, 200 x 325 mm or 255 x 255 mm).
- Check vision panels are sound and firmly installed and are fitted with full perimeter glazing tape and glazing beads.
- Check any mastic is approved type according to the specification.
- Check door performance label is attached to door leaf and frame and is minimum 50 x 25 mm.
- Door frame label contains:
 - name of the certifier
 - name of the manufacturer
 - FRR of the doorset in minutes.
- Door leaf label (see above) contains:
 - number of the standard (NZS 4520:2010 or AS/NZS 1905.1:1997)
 - FRR in minutes
 - name of the manufacturer/sponsor
 - name of the applicant
 - name of the certifier
 - year of manufacture.

Applicable standards: NZS 4520:2010, AS/NZS 1905.1:1997, AS 1851-2012, AS 1530.4-2005.

Checklist 3: Shutters

Shutter types include:

- steel roller
- fabric roller or concertina
- horizontal composite shutter with concertina action.

This checklist addresses specific items for the installation of shutters:

- Obtain copies of site installation specification and consent documents.
- Obtain copies of product specification/certificates/reports or other documents such as a letter of opinion or assessment from a competent authority.
- Is roller shutter approved for the relevant type of wall (masonry, plasterboard etc.)?
- Are openings (apertures) prepared to the job specification or requirements of the installer?
- Check barrel to ensure:
 - barrel brackets are securely fixed
 - the rolled-up curtain on the barrel will sit higher than the top level of the guide tracks (leading edge of curtain sits in guides)
 - the supporting bracket is securely fixed to the wall using an identical method to that of the tested or approved specimen.
- Check curtain - when the bottom rail is in contact with the threshold, the curtain must be in contact with not less than 50% of the circumference of the barrel assembly.
- Check vertical guides to ensure:
 - they are securely fixed
 - the curtain overlaps the jamb approximately equally on each side of the opening
 - the overlap is equal to or greater than that provided in the tested specimen
 - the gap between the end of the slats including end clips and the guide track is no less than that provided in the tested specimen or as per specification
 - the guide rail is fastened to the wall in an identical method to that of the tested specimen
 - the curtain can run freely without jamming.
- Check that the fusible link:
 - has a temperature rating not greater than 80°C (57°C in the case of a drenched shutter)
 - is located on the same side of the opening as the barrel, no further than 250 mm from the barrel
 - is exposed to the general airflow when this is an option
 - for openings greater than 4.0 m wide, has two fusible links in series, one located at each end of the opening.
- Verify site inspection by the manufacturer or agent or provide the installer's declaration.
- Label size is minimum 50 x 25 mm and fixed mechanically (no adhesive) to the bottom rail of roller shutter.
- Check label information includes:
 - name of the manufacturer or certifier
 - identification number of the individual fire-resistant roller shutter
 - FRR

- date of installation
 - a note stating that the supplier or certifier certifies that the fire-resistant roller shutter and installation comply with the requirements of AS 1905.2-2005 *Components for the protection of openings in fire-resistant walls - Fire-resistant roller shutters* (not specified in NZBC C/AS1-6 but a useful guide).
- Does shutter close when fusible link released?
 - Does shutter close on alarm if alarm activated?
 - Check curtain descends to the threshold at an average speed of between 0.15 m/s and 0.3 m/s.
 - Check shutter curtain does not rebound more than 25 mm on closing.
 - Check sill complies with specification as not deemed combustible and extends either side at least 150 mm.

Applicable standards: AS 1530.4-2005, NZS/BS 476.22:1987 *Fire tests on building materials and structures - Methods for determination of fire resistance of non-loadbearing elements of construction*.

Checklist 4: Ducts

Duct types include:

- steel casings with fire protection - mineral/ceramic wool blanket, rigid boards (for example, plasterboard, calcium silicate, vermiculite based, magnesium oxide) or cementitious spray
- self-supporting (no casing), for example, calcium silicate, vermiculite based, magnesium oxide.

This checklist addresses specific items for the installation of fire-rated ducts:

- Obtain copies of site installation specification and consent documents.
- Obtain compartmentation plan.
- Obtain copies of product specification/certificates/reports or other documents such as a letter of opinion or assessment from a competent authority.
- Is the duct approved for the wall/floor type?
- Are wall (or floor) openings (apertures) prepared to the job specification or requirements of the installer?
- Check that any apertures greater than specified dimensions are made good with materials that maintain the FRR of the wall (or floor) and are capable of supporting the duct.
- Is the opening structurally sound with lintels as appropriate?
- Is the wall or floor sound and constructed to the correct FRR?
- Are duct materials as per specification - steel, thickness, protection type, supports, penetration seal?
- Is the duct installed as per specification?
 - Note: The duct must not be used to support a wall unless approved.
 - Are penetrations in the wall or floor sealed as specified?
 - Is fire stopping, if any, between the duct and wall as per specification?
 - Is the duct supported as per specification (on wall or floor or on hangers)?
 - Is the hanger spacing as specified?
 - Is the duct clear of obstructions?
- Fire protection is applied as specified:
 - Thickness.
 - Number of layers.
 - Fixings.

Applicable standards: AS/NZS 1668.1:1998 *The use of ventilation and airconditioning in buildings - Fire and smoke control in multi-compartment buildings*, AS 1530.4-2005.

Checklist 5: Fire dampers

Damper types include:

- steel mechanical dampers - interlocking blade shutters, individual rotating blades or single blade (circular)
- intumescent dampers.

Mechanical dampers invariably require retaining angles, whereas intumescent dampers may not need any. Check the manufacturer's specifications.

This checklist addresses specific items for the installation of fire dampers:

- Obtain copies of site installation specification and consent documents.
- Obtain the compartmentation plan.
- Obtain copies of product specification/certificates/reports or other documents such as a letter of opinion or assessment from a competent authority.
- Is the damper approved for the wall/floor type?
- Have the wall (or floor) openings (apertures) been prepared to the job specification or requirements of the installer? (Note: For metal dampers, aperture dimensions are to be 10 mm plus 1.01 x the damper outer dimensions or as per specification.)
- Check that any apertures made larger than specified dimension have been made good with materials that maintain the FRR of the wall (or floor) and are capable of supporting the damper.
- Ensure the opening is structurally sound with lintels as appropriate.
- Is the wall or floor sound and the correct FRR?
- Is the damper installed as per specification?
 - Note: The damper must not be used to support a wall unless approved.
 - Are perimeter angles, if any, flush with wall and correct overlap on wall (at least two times the clearance between the fire damper body and the penetration)?
 - Is fire stopping, if any, between damper and wall as per specification?
 - Is the damper supported as per specification (on wall or floor or on hangers)? (Support by ductwork is not usually permitted.)
 - Is the damper installed in the correct direction relative to the airflow?
 - Do blades open and are they free to move and latch?
 - Is the damper free of obstructions?
 - Check that elements of an intumescent damper are correctly aligned (not bent or out of shape).
- Check there is no combustible material on or in proximity of the damper at the wall unless part of the specification.
- Are access hatches clear and unobstructed?
- Does ceiling access coincide with the duct access panel?
- Is there a label attached with the following information?
 - Manufacturer's name.
 - Model and test report number. (If the model number is traceable to the relevant test reports, the model number alone will suffice.)
 - FRR.
 - Orientation (vertical, horizontal or both).
 - Direction of airflow.

- If appropriate, words or a symbol indicating suitability for use in an aggressive environment.
- Clearances between the damper and penetrated element.
- Check any breakaway joint and connection to ducting (slip joint, nylon, aluminium fixings).
- Take record photo with angles off and angles on.

Applicable standards: AS 1682.1-1990 *Fire dampers - Specification*, AS 1682.2-1990 *Fire dampers - Installation*, AS 1530.4-2005.

Checklist 6: Penetration seals

Penetration seal products include:

- mastics, in tube or pail, for lineal gap seals (control joints), wall joints (perimeter of walls) or pipes
- foams
- putties
- mineral boards, with or without a coating
- mortars
- pillows
- wraps
- collars
- sleeves
- blocks and plugs.

Penetration types include:

- pipes
- cables in singles, bundles or on cable trays
- ducts, dampers (see above)
- control joints
- lineal gap seals (control joints)
- wall joints (perimeter of walls).

This checklist addresses specific items for the installation of penetration seals where services pass through fire-rated wall and floor construction:

- Obtain copies of site installation specification and consent documents.
- Obtain the compartmentation plan.
- Obtain copies of product specification.
- Is the penetration seal approved for the wall/floor type (masonry, plasterboard etc.)?
- Is the penetration seal approved for the penetration and its application (floor waste, plastic pipe, steel pipe, cable tray, control joint)?
- Are wall (or floor) openings (apertures) prepared to the job specification or the requirements of the installer?
- Are any apertures greater than specified dimensions or badly formed (i.e. chipped edges, irregular)? These should be made good with materials that maintain the FRR of the wall (or floor) and are capable of supporting the seal.
- Is the opening structurally sound with lintels as appropriate?
- Is the wall or floor sound and of appropriate FRR?
- Are pipes supported as specified by the manufacturer or tested if report available?
- Seal is installed as per specification:
 - Both sides or one side of floor, wall or ceiling.
 - Filled to correct depth, for example, mastics and pillows.
 - Either surface mounted or within wall.
 - With pipe, cable tray etc. supports at correct spacing from the wall.
 - With appropriate backing material if required.
 - With radiation shields or insulation to metal pipes or as per specification.
 - With correct fixings to the building element.

- Check penetration label includes (if provided):
 - number of the applicable standard
 - FRR in minutes
 - name and details of the installer
 - installation date
 - unique installation reference number
 - name of the manufacturer.

Applicable standards: AS 4072.1-2005, AS 1530.4-2005.

<p>Fire and smoke containment barrier and penetration system (to AS 1530.4 and AS 4072.1) FRR: -/60/60</p> <p>Installed by (company name):.....</p> <p>Phone no:.....</p> <p>Installation date:.....</p> <p>Installation reference:.....</p> <p>Contact the above in the event of damage or if reinstatement is required</p>
--



Guide to Passive Fire Protection in Buildings



BRANZ LTD
1222 Moonshine Road, RDI, Porirua 5381
Private Bag 50908, Porirua 5240, New Zealand
T +64 4 237 1170 F +64 4 237 1171
E branz@branz.co.nz
www.branz.nz

978-1-927258-75-0 (PDF)

978-1-927258-76-7 (epub)